

Serial No:

Model:	COH110	COH180	COH220	COH280
--------	--------	--------	--------	--------

WARNING: If the information in these instructions are not followed exactly, a fire may result causing property damage, personal injury or death.

- Installation and service must be performed by a qualified installer or service agency.

THIS APPLIANCE MUST BE INSTALLED-

- BY A COMPETENT PERSON
- IN ACCORDANCE WITH THE RULES IN FORCE
- IN ACCORDANCE WITH INSTALLATION & SERVICING INSTRUCTIONS.
- IN OPEN AIR OR IN A ROOM WHICH IS SEPARATED FROM LIVING ROOMS AND PROVIDED WITH APPROPRIATE VENTILATION DIRECTLY TO THE OUTSIDE

READ THESE INSTRUCTIONS BEFORE INSTALLING AND OPERATING THE APPLIANCE

THIS MANUAL SHOULD BE MAINTAINED IN LEGIBLE CONDITION AND KEPT ADJACENT TO THE HEATER OR KEPT IN A SAFE PLACE FOR FUTURE REFERENCE.



Operating, Installation and Servicing Instructions for

Certikin

Oil Fired Pool & Spa Heater

M3491

HEALTH AND SAFETY

INFORMATION FOR THE INSTALLER AND SERVICE ENGINEER.

Under the Consumer Protection Act 1987 and the Health and Safety at Work Act 1974, it is a requirement to provide information on substances hazardous to health (COSHH Regulations 1988).

The Company takes every reasonable care to ensure that these products are designed and constructed to meet these general safety requirements, when properly used and installed.

To fulfil this requirement products are comprehensively tested and examined before despatch.

This appliance may contain some of the materials below.

When working on the appliance it is the Users/Engineers responsibility to ensure that any necessary personal protective clothing or equipment is worn appropriate to parts that could be considered as being hazardous to health and safety.

INSULATION & SEALS

Glass Rope, Mineral Wool, Insulation Pads, Ceramic Fibre, Fibre Glass Insulation: may be harmful if inhaled, may be irritating to the skin, eyes, nose or throat. When handling avoid inhalation and contact with the skin or eyes. Use (disposable) gloves, face masks and eye protection. After handling wash hands and other exposed parts. When disposing, reduce dust with water spray, ensure parts are securely wrapped.

GLUES, SEALANTS & PAINT

Glues, Sealants and Paint are used in the product and present no known hazards when used in the manner for which they are intended.

KEROSENE & GAS OIL FUELS (MINERAL OILS)

1. The effect of mineral oils on the skin vary according to the duration of exposure.
2. The lighter fractions also remove the protective grease normally present on the surface of the skin rendering the skin dry, liable to crack and more prone to damage caused by cuts and abrasions.
3. Skin rashes (oil Acne). Seek immediate medical attention for any rash, wart or sore developing on any part of the body, particularly the scrotum.
4. Avoid as far as possible any skin contact with mineral oil or with clothing contaminated with mineral oil.
5. Never breath any mineral oil vapours. Do not fire the Burner in the open i.e. out of the Boiler as a misfire will cause unburnt oil vapours.
6. Barrier cream containing lanolin such as Rosalex Antisolv, is highly recommended together with a strict routine of personal cleansing.
7. Under no circumstances should mineral oils be taken internally.

OFTEC Code of Practice OCP/1: 1995 For the Safe Installation, Commissioning, Maintenance and Fault Rectification of Oil Firing Equipment should be consulted.

Due to a policy of continual development the Manufacturer reserves the right to alter or amend the design of its products without prior notice.

CONTENTS

SECTION 1 - USER INSTRUCTIONS

- 1:1 Safety Notes
- 1:2 Air Supply
- 1:3 Connections
- 1:4 Installation & Commissioning
- 1:5 Quick Start
- 1:6 Summary of Controls
- 1:7 Re-pressurising
- 1:8 Running the Pool Pump
- 1:9 Switching off, temporarily
- 1:10 Switching off for the winter
- 1:11 Oil delivery
- 1:12 Maintenance
- 1:13 Trouble shooting
- 1:14 Service
- 1:15 Water Quality

SECTION 2 - GENERAL INFORMATION

- 2:1 Introduction
- 2:2 Patents
- 2:3 Flue Options
- 2:4 Commissioning
- 2:5 Safety

SECTION 3 - TECHNICAL DATA

- 3:1 Liquid Fuels
- 3:2 Heater Technical Details
- 3:3 Burner Details
- 3:4 Electrics
- 3:5 Dimensions
- 3:6 Commissioning Data

SECTION 4 - INSTALLATION

- 4:1 Standards and Regulations
- 4:2 Heater Controls
- 4:3 Installation Wiring
- 4:4 If combined with heating
- 4:5 Siting & Positioning
- 4:6 The Hearth
- 4:7 Oil Storage
- 4:8 Oil Supply
- 4:9 Oil Burner
- 4:10 Sensor positions
- 4:11 Wiring Diagrams

SECTION 5 - FLUES

- 5:1 Conventional Flues
- 5:2 Air Supply
- 5:3 Balanced Flue Heaters
- 5:4 Balanced Flue Terminals
- 5:5 Terminal Guards
- 5:6 Positioning the Heater

SECTION 6 - BALANCED FLUE INSTALLATION

- 6:1 General Information
- 6:2 Horizontal Balanced Flues
- 6:3 Vertical Balanced Flues
- 6:4 Outdoor Flue Kits

SECTION 7 - COMMISSIONING

- 7:1 General Information
- 7:2 Filling the Heater
- 7:3 Setting up the Controls
- 7:4 Pressure Switch
- 7:5 Responsibility
- 7:6 Reporting
- 7:7 Commissioning Check List
- 7:8 Commissioning Tests

SECTION 8 - MAINTENANCE

- 8:1 Maintenance
- 8:2 Air Shutter Adjustment
- 8:3 Baffle Arrangement

SECTION 9 - SPARES & ACCESSORIES

- 9:1 Spare Parts
- 9:2 Accessories
- 9:3 Burner Parts

SECTION 10 - FAULT FINDING

- 10:1 General
- 10:2 Control Fault Diagnosis
- 10:3 Fault Finding Chart

1: USER INSTRUCTIONS

1:1 Important Safety Notes

To obtain the best possible performance and trouble free operation from your Heater, it is important that you read these instructions carefully. Your Pool Heater has built-in safety features, which are detailed in the relevant section of this manual.

Please note: It is essential in the interest of the Heater efficiency and reliable performance that once the Heater has been installed it is first commissioned by an OFTEC.* registered engineer. It is the responsibility of the installer to ensure that the Heater is commissioned.

If an engineer is not known, The Manufacturer will be pleased to provide details of an approved commissioning and servicing engineer from their list of approved engineers.

If it is known or suspected that a fault exists on the Heater, it MUST NOT be used until the fault has been corrected by a competent engineer (see Section 1:13, Trouble Shooting - Failure to Start)

It is essential that these instructions are strictly followed for safe and economic operation. Failure to observe these instructions may invalidate your right to free breakdown cover during the guarantee period.

As this an oil burner appliance some parts will become very hot and so care must be taken.

We recommend that you keep these instructions in a place near your Heater for easy reference.

1:2 Air Supply to Heater - Conventional Flue

Where your Heater is used on an open conventional flue system, a permanent air supply is required for combustion. Clearances provided for air entry at the rear of the appliance and into the building in which it is installed, must be kept free of obstruction. For further explanation please refer to section 5:1 and 5:2.

1:3 Connections

Your Heater should be connected to an electrical supply complying with the Electrical Wiring Regulations (BS7671): as well as an oil supply complying with BS541; and an appropriate flue system. ALWAYS SWITCH OFF THE ELECTRICAL SUPPLY before removing any of the covers for cleaning.

If any part of the Heater or its flue is modified then the guarantee will be invalidated.

1:4 Installation & Commissioning

After your Heater has been installed it MUST be commissioned preferably by an OFTEC*. Registered installer, or by one of our recommended service engineers. Commissioning involves testing the Heater to ensure that it is working correctly, and also setting the Burner correctly to ensure the most efficient operation and use of fuel. If the Heater has not been commissioned, it may not be operating at the maximum efficiency possible, and may also invalidate the guarantee.

*The Oil Firing Technical Association for the Petroleum Industry 0845 6585080.

1:5 Quick Start

Check the Electricity and Oil supplies to the Heater are on. If the Pool Pump is not controlled by the Heater, turn it on. Turn on the Heater by turning the Pool Temperature Control Knob clockwise to show the required Pool temperature, the Heater will fire. If the Heater fails to light see Section 1:13, Trouble Shooting - Failure to Start)

1:6 Summary of Controls (left to right)

Boiler Pressure Gauge

Normal - The needle should be in the area indicated as ** NORMAL **, if low, re-pressurise, see Section 1:7

Pool Demand LED - GREEN

Off - There is no Pool Heating Demand , pool heating is off.

On - There is a Pool Heating Demand the pool is not yet up to temperature.

Flashing - The Pool Heating Demand is Met , the pool is up to temperature.

Pool Temperature Control Knob

16°C to 41°C (60°F to 106°F)

Off - There is no Pool Heating Demand , pool heating is off.

Pump - Runs Pool Pump only, if connected via heater. 'P' is indicated on Pool Temperature Display.

- **Pool +** - Setting for pool temperatures. Requested temperature is displayed when setting, actual Pool Temperature is displayed after 3 seconds.

- **Spa +** - Setting for Spa Temperatures. Required temperature is displayed when setting, actual Spa Temperature displayed after 3 seconds.

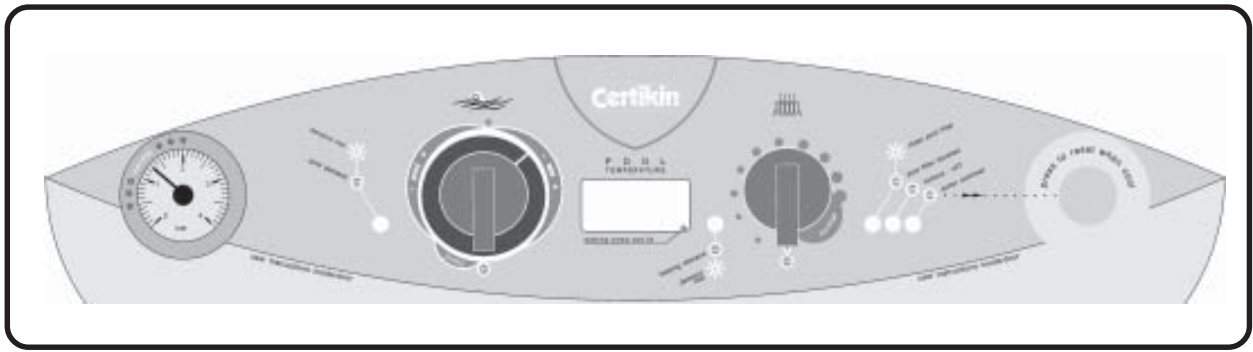

(NOTE: The Heater is delivered set to display in Fahrenheit. For a Centigrade display, see 7:3 Commissioning Section of Installation Instructions)

Pool Temperature Mechanical Stop

Stop – This can be used to obtain a repeatable setting and to limit maximum pool temperature. To set, loosen the screw, adjust as required and then re-tighten.

Pool Temperature Display

Display - Normally shows the actual Pool Temperature, but also displays the Setting Temperature and a Setting Dot lit whilst being adjusted. The display is also used for commissioning and diagnostic purposes.

Heating Demand LED - GREEN

(Only in use when heating system connected)

Off - There is no Heating Demand, heating is switched off.

On - There is a Heating Demand, heating is on but not yet up to temperature.

Flashing - The Heating Demand is Met, heating is up to temperature.

Heating Temperature Control Knob

(Only used when heating system connected)

Off - There is no Heating Demand, heating is switched off.

Normal - Normal setting for heating, it can be adjusted lower if required.

(NOTE: Supplied set for Pool Priority. It will satisfy the Pool Temperature before supplying full Heating. To change the priority, see 7:3 Commissioning Section of the Installation Instructions)

Filter LED - YELLOW

On - Pool Filter Blocked - Insufficient pressure, possibly due to a blocked pool filter. The heater will not run.

Flashing - Clean Pool Filter - The filter may require

back washing. The heater will run. Can be reset by turning the Pool Temperature knob off and back on again.

Lockout - Oil? LED - RED

On - Lockout - Oil? - This indicates that the burner cannot fire, the probable cause is lack of fuel oil. Check the oil tank. After 3 minutes press the Button on the front of the Burner to reset. If the problem persists consult your Service Engineer.

Boiler Overheat LED - RED

On - Boiler Overheat - This indicates that the Heater has overheated and shut down. See Press to Reset Button instructions below.

Press to Reset Button

Press - Press Reset Button when boiler has cooled down. If the problem persists consult your Service Engineer.

Automatic Frost Protection

The Heater will automatically run a Frost Protection routine if the temperature falls below 3°C (37°F). The Pool Temperature Display will show 0°C. This will include the use of the Pool Pump if connected to the Heater.

1:7 Re-Pressurising

Connect a Mains Water supply then connect the free end of the braided flexible hose (the Filling Loop) (see Fig.2:1b) to the incoming mains connector.

Open the Valve to the supply, then, slowly open the Valve on the Side Panel until the Pressure Gauge shows 1 Bar.

Close both valves then disconnect the Filling Loop.

1:8 Running the Pool Pump

If this option has been installed the Heater can run the Pool Pump on its own. Turn the Pool Temperature Control Knob to 'Pump', just next to Off.

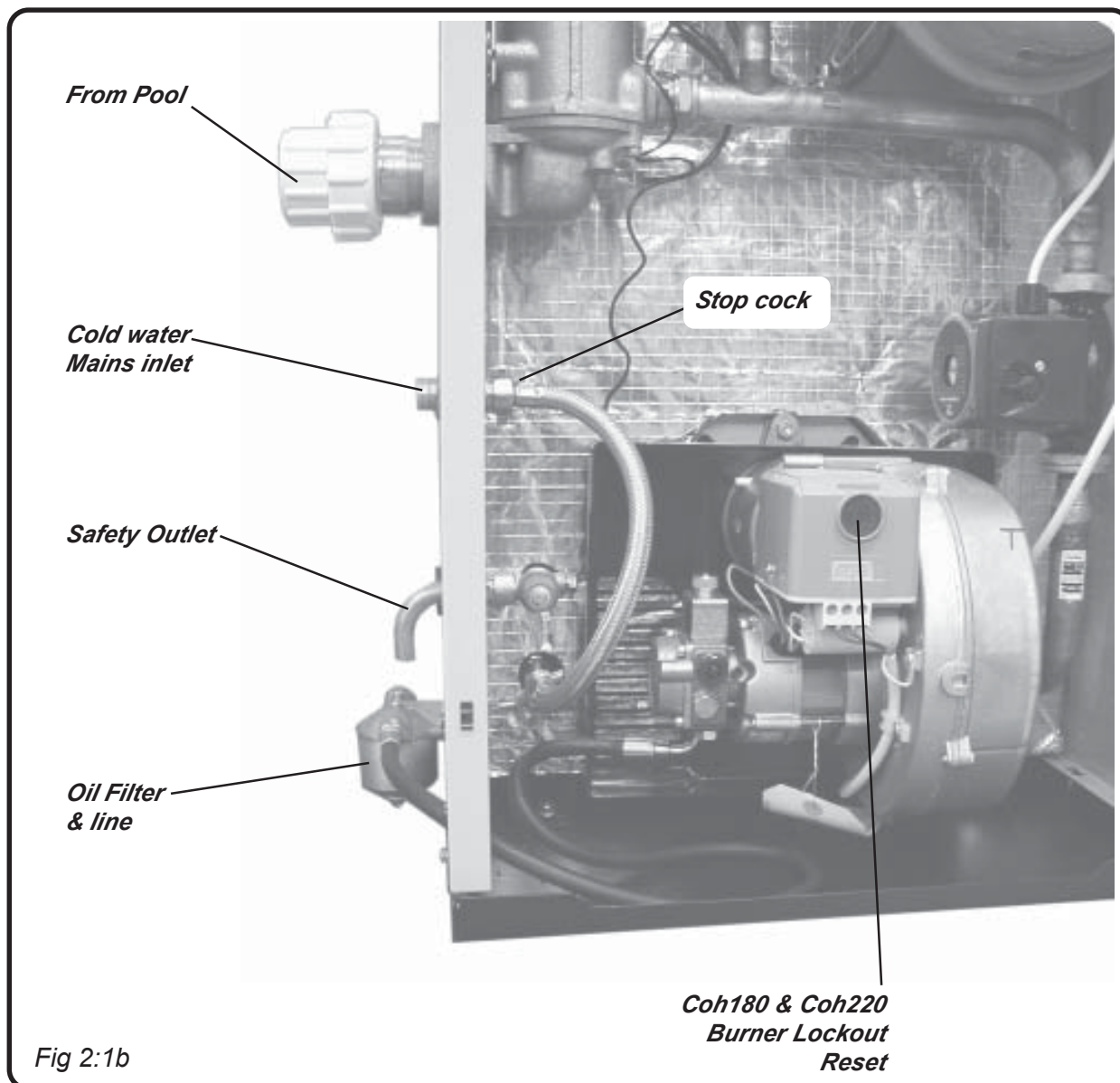

1:9 Switching the Heater Off - temporarily

The Heater may be stopped by turning the Pool Temperature Control Knob and/or the Heating Temperature Control Knob to OFF on Control Panel. Alternatively, the Heater may be stopped by turning off the mains switch controlling the Heater.

1:10 Switching off for the Winter

Turn both Temperature Control Knobs to Off.
If the built in Frost Protection is required do not isolate the Heater from its electrical supply.
If the Heater is to be shut off for the Winter, it is advisable to have it thoroughly serviced when first shut down. Thorough cleaning will minimise corrosion during the idle period. Remember, when the Heater is required, to ensure that the oil supply is open before switching on.

1:11 Oil Delivery

Always ensure the tank is topped up at regular intervals rather than wait till it is nearly empty. This will avoid sludge and water being sucked in to the burner.

Where possible, it is advisable to temporarily switch the Heater off, and to keep it off for one hour after the delivery. This is to allow any sediment to settle and not be drawn into the Heater. If you do not, this could result in an inconvenient breakdown.

Please ask your supplier, or the driver to notify you before the oil is discharged.

1:12 Maintenance

For normal cleaning of the outside casing, simply wipe with a dry cloth. To remove stubborn marks and stains, wipe with a damp cloth and finish off with a dry cloth. DO NOT use abrasive cleaning materials. A spray of WD40 or similar will also help to protect it.

The Heater must be serviced at regular intervals by a qualified service engineer. Failure to have the Heater serviced at the recommended intervals will invalidate the guarantee.

If using Kerosine Class C2 fuel, the Heater should be serviced at twelve monthly intervals.

If using Gas Oil Class D fuel, the Heater should be serviced at six monthly intervals.

All air intakes must remain clear at all times and so it is advisable to inspect and clean these areas regularly. Please refer to 4:6 later in this Installation manual for further explanation.

1:13 Trouble Shooting - Failure to Start

If the Burner fails to start, adopt the following procedure:-

1. Check that there is oil in the tank and that the supply valve is open.
2. Check that the Pool pump is operating and that the Filter lamp is not illuminated.
3. Check that the Heater Control Thermostat is set high enough to be "ON" and that the Pool Demand lamp is on.
4. Check whether the Boiler Overheat light on the control fascia is glowing, if so it indicates an overheat situation. Press the Reset Button once the temperature has dropped sufficiently.
5. Check whether the red Lockout indicator on the Control Panel and Burner Control box are glowing. This indicates that the Burner has attempted to start but has not fired successfully. Press the reset button on the Control box, when released, the lights will go out and the Burner will again attempt to start. If the Burner does not run and again goes to lockout with red indicators glowing:-
 - Wait three minutes.
 - Repeat the procedure by pressing the button.
 - Failure to start on the second attempt indicates a fault requiring attention.
 - Switch off the mains supply and call your service engineer.

1:14 Servicing

To ensure efficient and reliable operation of the Heater it is essential that the oil burner is initially commissioned by a qualified engineer, and that an annual service is given thereafter by an OFTEC trained and registered engineer.

1:15 Water Quality

Chemical imbalance can cause severe damage to your Heater and associated equipment.

Maintain the water pH between 7.4 and 7.6 and ensure that the free chlorine levels are within the range recommended by the chemicals manufacturer for your size of pool.

Check the Filter regularly and keep the pool free of debris such as leaves and grass cuttings.

2: GENERAL INFORMATION

2:1 INTRODUCTION

This Manual covers Operation, Installation, Commissioning and Maintenance of the Oil Fired Pool Heaters.

The Pool Heaters are :-

- Designed for heating pools and Spas by utilising an internal water to water heat exchanger.
- Incorporates its own sealed system components; pressure vessel, filling loop, safety valve, and pressure gauge.
- Can also be used for space heating.
- Supplied with a manual reset limit thermostat.
- Suitable for new installations and for replacing existing Heaters.
- Include an internal thermostatic bypass to maximise the life of the heat exchanger.

All models are supplied as standard with a low level horizontal firing Oil Burner suitable for connection to a conventional flue.

Note: The nozzle on this appliance is only covered by a 1 year guarantee.

2:2 PATENTS

The internal baffling system is subject to pending Patent Application No. GB 9409095.8

2:3 FLUE OPTIONS

The Heaters are designed to operate with high efficiency compliant with Section L of the Building Regulations, clean combustion, and low noise levels.

Choice of flue systems are as follows:

- For connection to a conventional flue.
- Low level balanced flue, left, right or rear.
- Outdoor.
- Vertical Balanced flue.

See **Section 9:2** for parts/accessories detail.

The tested balanced flue terminal and connection affords an adequate supply of air for combustion and equalisation of pressure between exhaust and intake as required for operation under unfavourable wind conditions.

Balanced flues are supplied in a carton that includes ALL parts for a balanced flue installation.

The horizontal terminals are designed to avoid the possibility of staining outer walls through which they pass.

2:4 COMMISSIONING

It is essential in the interest of Heater efficiency and reliable performance that once the Heater has been installed it is first commissioned by a qualified engineer.

If an engineer is not known, The Manufacturer will be pleased to provide details of an OFTEC* approved commissioning and servicing engineer from their list of approved engineers.

See Section 7 for Commissioning Procedure.

It is the responsibility of the Installer to ensure that the Heater is commissioned by an OFTEC* Registered Commissioning Engineer.

**The Oil Firing Technical Association for the Petroleum Industry, Banstead, Surrey Tel: 0845 6585080.*

2:5 SAFETY

READ THE HEALTH AND SAFETY INFORMATION ON THE INSIDE FRONT COVER OF THIS MANUAL.

Should you wish to remove or dismantle any covers or parts of the Heater for cleaning or maintenance ALWAYS FIRST SWITCH OFF THE ELECTRICITY SUPPLY.

1. On no account should any part of the Heater or its Flue be modified.
2. The wiring of the control panel should be as the wiring diagrams included in this Manual. Wiring should not be tampered with, modified or changed for any reason.
3. Only use The Manufacturer's replacement parts. Noncompliance with the above will invalidate the Guarantee.

3: TECHNICAL DATA

3:1 LIQUID FUELS

The Pool Heaters will burn liquid fuels complying with BS2869 Part 2 1988 Classes C2 and D as specified in the Code of Practice for Oil Firing BS5410 Part 1.

Class C2 (Kerosine)

This fuel is suitable for all models. Burners are supplied with the appropriate nozzle and pump pressure as standard for this fuel.

They are set for the stated output. Details of all nozzle sizes and pump pressure for all Heaters are shown on the following pages.

Class D (Gas Oil)

All models, can be adapted to burn Class D Gas Oil. The adaptation requires the alterations as detailed in the datatable 3:6.2.

The use of Class D (Gas Oil) for low level discharge of combustion gases is NOT permitted under any circumstances.

(Ref: Oftec Technical Book 1).

3:2 HEATER TECHNICAL DETAILS

Maximum Heater working pressure	3 Bar (Class 2) 30.6m Water Head
Maximum hearth temperature	less than 85°C
Maximum side panel temperature above room.	less than 35°C
Minimum Conventional flue draught at Heater flue outlet	0.035"w.g. (8.75N/m ²).
Maximum Conventional flue draught at Heater flue outlet	0.15"w.g. (37.5N/m ²).
Water Resistance with 11°C temperature rise across the Heater	0.3m (1ft) wg
Recommended Filling Pressure	1 bar
Expansion Vessel	4 litres, pre-charge pressure 1 bar
Fuses	Heater Control 5 Amp 250mA Anti-surge glass LRC
Pool Pump Output, maximum	3 Amp, 230V

3:3 BURNER DETAILS

Burner - Reillo 40, 443T58, 459T55, 464T55. and RDB3 489T50

Manually adjustable air regulator.

For further details of the burners, refer to the data sheets supplied in the literature pack.

3:4 ELECTRICS

Electrical Supply 230v., 1 Ph., 50Hz.

All wiring to the supply and all system components external to Heater must comply with the latest edition of BS7671 IEE Wiring Regulations. This appliance must be effectively earthed and connection to the supply must be through a double pole isolating switch.

Note: Pool Heaters with Outdoor Flue Kits.

IMPORTANT: THE OIL POOL HEATER IS SUPPLIED WITH A 13 AMP PLUG, THIS SHOULD NOT BE USED OUTDOORS. ENSURE POWER SUPPLY IS IN ACCORDANCE WITH I.E.E. REGULATIONS AND ANY LOCAL REGULATIONS WHICH APPLY.

3:5 DIMENSIONS

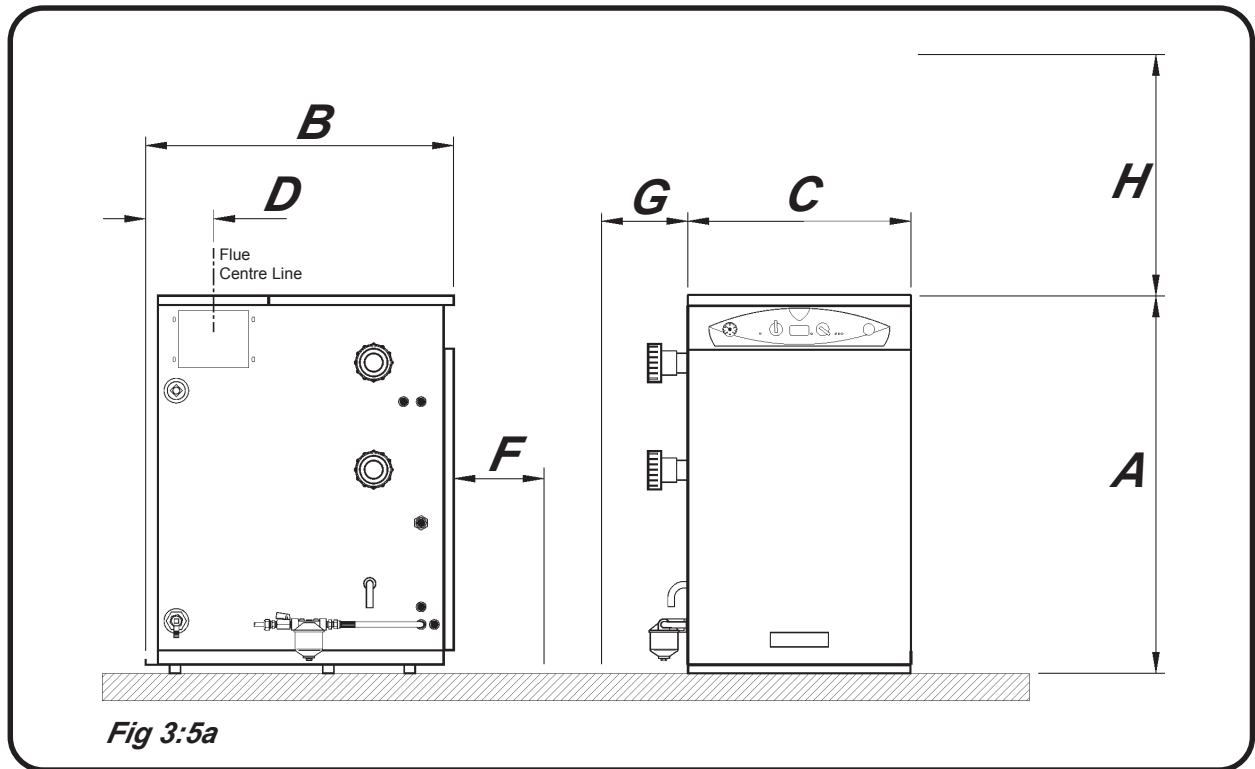

Model	Height	Depth	Widths		Flue Dia. *	Service Clearances			Int' Pump Speed	Pool Connection mm	Water Content litres	Weight Empty kg
	A mm	B mm	C mm	D mm		F mm	G mm	H mm				
110	860	700	470	127	100	750	500	500	1	38	30	130
180	1000	725	510	169	125	750	500	500	2	38	38	190
220	1000	725	510	169	125	750	500	500	3	38	38	190
280	1100	870	590	191	150	750	500	500	2	38	59	310

*Conventional flue sizes

3:6 COMMISSIONING DATA

3:6.1 Class C2 Kerosine Oil, Riello Burner.

Model	Output		Burner		Nozzle US/GPH / Angle	Pump Pressure		Air Shutter	Firing Rate l/h	CO ₂ %	Smoke	Flue Gas Temp°C Gross
	kW	Btu/h x 1000	Type	Head Setting		Bar	psi					
110	26.4	90	443T58	Fixed	0.85x60W	7.1	105	3.1	3.04	12	0 - 1	190
180	44	150	459T55	3	1.35x60W	8.2	120	3.1	5.06	12	0 - 1	204
220	51	175	464T55	2	1.75x60W	6.8	100	4.5	6.07	12	0 - 1	240
280	70	239	489T50	Fixed	2.25x60W	7.5	110	8.5	8.13	12	0 - 1	200

3:6.2 Class D, Gas Oil **NOTE: Low Level discharge is NOT allowed**

Model	Output		Burner		Nozzle US/GPH / Angle	Pump Pressure		Air Shutter	Firing Rate l/h	CO ₂ %S	Smoke	Flue Gas Temp ^o C Gross
	kW	Btu/h x 1000	Type	Head Setting		Bar	psi					
110	26.4	90	443T58	Fixed	0.75x60W	7.1	105	3.0	2.88	12	0 - 1	200
180	44	150	459T55	4	1.10x60W	9.2	135	4.0	4.84	12	0 - 1	220
220	51	175	464T55	2	1.25x60W	10.2	150	3.5	5.82	12	0 - 1	240
280	70	239	489T50	Fixed	1.65 x 60W	10.9	160	8.0	7.76	12	0 - 1	206

Gas Oil Conversion Components

Model	Nozzel	Pre-Heater	Flame Ring	Bottom Baffle
110	SPCOH2/009	SPCOH2/008	Not required	As Supplied
180	SPCOH2	SPCOH001	Not required	As Supplied
220	SPCOH26	Not required	Not required	As Supplied
280	SPCOH2/012	Not required	SPCOH2/013	Remove

4: INSTALLATION

4:1 STANDARDS & REGULATIONS

The installation of the Heater must comply with latest edition of :-

BS 5410: Oil Installations

Pt 1 under 44kW

Pt 2 over 44kW

BS 5449: Forced circulation hot water central heating systems for domestic premises.

BS 4543: Pt. 1 & 3 Factory made insulated chimneys.

BS 7671: Electrical Wiring Regulations.

BS 7593: Treatment of water in Hot Water heating systems

BUILDING REGULATIONS.

Part J & G England and Wales

Part F Section III Scotland

Part L Northern Ireland

The Control of Pollution (Oil) Regulations

Oil Heaters should be installed in accordance with good practice as recommended by OFTEC (Section. 2:4).

4:2 HEATER CONTROL

This Heater uses a control specifically designed for it and it has the following features:

A highly accurate Pool Thermostat , 16°C to 41°C (60°F to 106°F)

A Boiler Thermostat. Fixed for Pool, 84°C, variable for Heating 60 - 82°C.

A Frost Thermostat which runs the Internal and Pool Pump at 3°C or below but then fires the Heater alone if the temperature has not risen sufficiently.

A Return Thermostat operating an internal bypass for condensation reduction.

An Over Temperature Thermostat (Overheat).

Burner Control with Lockout.

Internal Pump control with run on.

Pool Pump control with run on and out-of-season exercise. (Requires external contactor)

Pool Temperature and Setting display. Engineer selectable °C or °F.

User Indicators for Pool, Heating, Lockout, Overheat, and Service.

Engineer indicators of all switched outputs for simple diagnosis.

Priority selection of Pool or Heating. Engineer selectable.

Memory of: Filter, Overheat and Lockout occurrences.

Sensor failure detection and indication.

Control self checking with fault indication.

For more detail see the Commissioning (7:1) and Fault Finding (10:1) sections.

4:3 INSTALLATION WIRING

The designs below are in order of preference, the CCP02 being the easiest, quickest and most comprehensive solution.

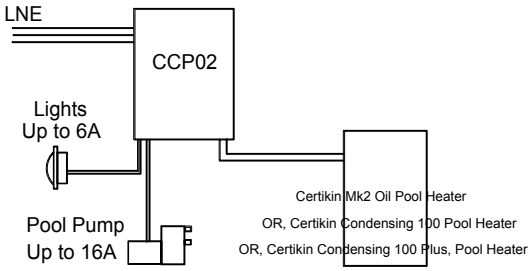
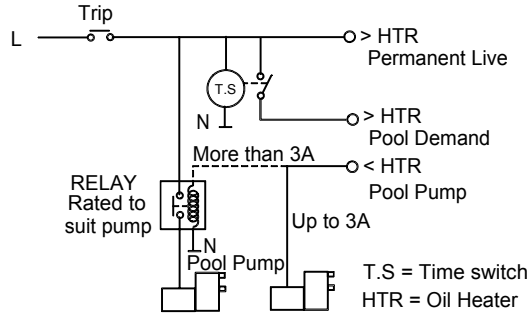
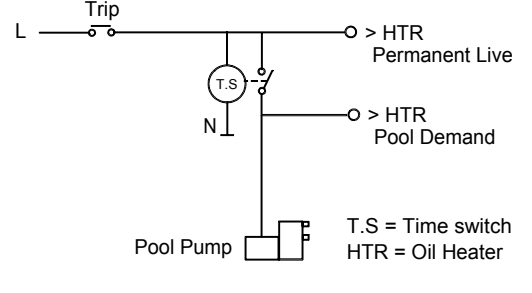
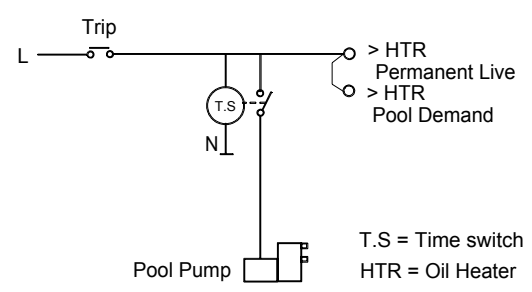
#	DESIGN	NOTES
1	 <p>Wiring diagram for Design 1: LNE (Live, Neutral, Earth) enters a CCP02 control unit. The CCP02 unit is connected to a light fixture (labeled 'Lights Up to 6A'), a pool pump (labeled 'Pool Pump Up to 16A'), and a Certikin Oil Pool Heater. The heater options are: Certikin Mk2 Oil Pool Heater, OR, Certikin Condensing 100 Pool Heater, OR, Certikin Condensing 100 Plus, Pool Heater.</p>	<p>Utilising the CCP02 "Quick Fit" Oil Pool Heater Control Takes full advantage of all the features of the Certikin Oil Pool Heater. Provides the fastest installation Pool Pump control providing overrun and Frost Protection action. Optional connections for Lights and Space Heating all provided.</p>
2	 <p>Wiring diagram for Design 2: A Trip switch is on the L line. A T.S. (Time Switch) is on the N line. A relay is connected to the L line, rated for the pool pump. Connections include: > HTR Permanent Live, > HTR Pool Demand, < HTR Pool Pump (Up to 3A). A note indicates 'More than 3A' for the pool pump. Legend: T.S = Time switch, HTR = Oil Heater.</p>	<p>Takes full advantage of all the features of the Certikin Oil Pool Heater. Considerable installation time. Pool Pump control providing overrun and Frost Protection action. Optional Space Heating only available with more wiring. Optional Lighting only available with more wiring.</p> <p>IMPORTANT: Remove link, Live to Pool Demand, in Heater</p>
3	 <p>Wiring diagram for Design 3: A Trip switch is on the L line. A T.S. (Time Switch) is on the N line. A Pool Pump is connected to the L line. Connections include: > HTR Permanent Live, > HTR Pool Demand. Legend: T.S = Time switch, HTR = Oil Heater.</p>	<p>Limited application of Certikin Oil Pool Heater. Moderate installation time. No Pool Pump control, Overrun or Frost Protection action. Optional Space Heating only available with more wiring. Optional Lighting only available with more wiring.</p> <p>IMPORTANT: Remove link, Live to Pool Demand, in Heater</p>
4	 <p>Wiring diagram for Design 4: A Trip switch is on the L line. A T.S. (Time Switch) is on the N line. A Pool Pump is connected to the L line. Connections include: > HTR Permanent Live, > HTR Pool Demand. Legend: T.S = Time switch, HTR = Oil Heater.</p>	<p>Non-preferred application of Certikin Oil Pool Heater. Moderate installation time. No Pool Pump control, overrun or Frost Protection action. Optional Space Heating only available with more wiring. Optional Lighting only available with more wiring.</p>

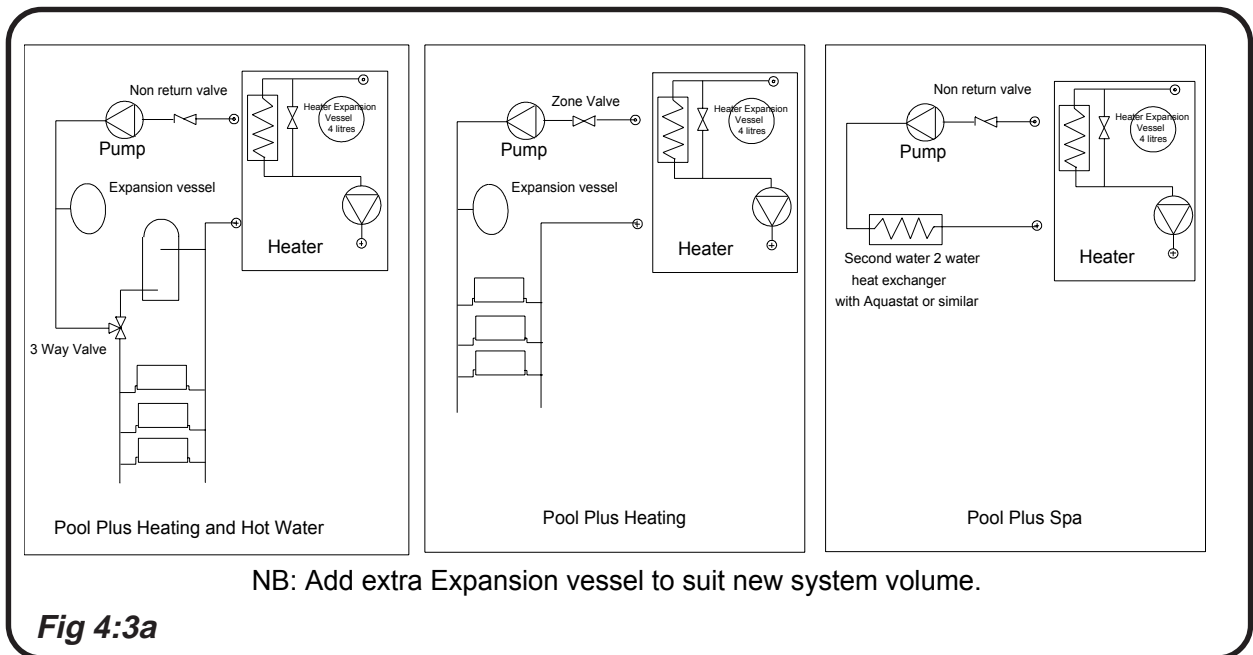

4:4 IF COMBINED WITH A HEATING SYSTEM

The Controls provide a water temperature control for use with a heating system, the Heating Demand Knob. It requires an electrical supply for Heating Demand to be connected as shown in the Wiring diagram and a pipe circuit to be connected to the two rear tappings of the Heater in place of the Air Vent and Drain. It is essential that an additional Expansion vessel is added for the additional system volume. Depending upon the Priority set (See commissioning, 7.1) the Pool or Heating will be brought up to temperature first. The Heating System should be installed in accordance with current good practice as advised by HVCA. Typical circuits are as follows.

4:5 SITING & POSITIONING

Consideration must be given to the following points.

1. Noise may be accentuated by the installation in small rooms or recesses with hard or hollow stud wall surfaces. Due consideration to the siting of Heaters should be given.
2. Some individuals may be particularly sensitive to even low noise levels and this should be discussed before installation.
3. The type of chimney, position relative to the Heater and whether a draught stabiliser is to be fitted may affect sound level in the room.

4. All models are serviced from the front and top. A space of 500mm (18") in front and above the Heater should be available.
5. Any kitchen work top above the Heater must be removable for service access.

4:6 THE HEARTH

All models have a Hearth Temperature of less than 85°C. The Heater requires a level hearth to stand on which should comply with the Building Regulations.

If the Heater is to stand on a floor made of combustible material then protection between the Heater and the floor should be provided by means of non-combustible material. Consideration should be given to the weight of the Heater and the Building Regulations regarding floor loading.

The filled Heater weight can be found in 3:5.

Advice should be sought from your local Building Control Office if there is any doubts regarding the floor supporting the Heater.

4:7 OIL STORAGE

4:7.1 Oil Tank

Consideration to the access by fuel delivery lorries should be given when positioning the oil tank.

Tank positioning should be in accordance with BS 5410 Part 1 and OFTEC Technical Book 3.

In the interest of most economical deliveries the Oil Tank should be of 3,000 litres (600 gallons) capacity.

It should be completed with the following:

1. Sludge Cock - on steel tanks.
2. Outlet Valve.
3. Contents Indicator.
4. Hinged Fill and Vent Cover or a separate Fill connection and Vent. The Fill and Vent should be suitably capped to prevent ingress of water or fitted with return bends

4:7.2 Steel Tanks

Tanks should be mounted on suitable supports, if these are of brick or blocks, a damp proof membrane should be inserted between the tank and its supports.

Tanks should slope 20 mm per metre of length downwards from the Oil Outlet to the Sludge Cock situated at the opposite end.

4:7.3 Plastic Oil Tanks.

Tanks made from plastic are now available. These should be UV stabilized for protection against sunlight, and coloured green. Plastic tanks do not need to stand on piers, but should be supported across the entire base area, ideally on 50 mm thick garden slabs or a concrete base. As there is only one tapped outlet they are more suited to single pipe feed as gravity supply or with a 3K Oil Loop Deaerator where suction lift is required. (Part No. BS 03060)

4:8 OIL SUPPLY

The oil connection points on the Heater casing are shown in the diagram **Fig 7:2c** in Section 7 of this manual.

All joints in the Oil Lines must be oil tight and the Oil Line should be flushed clean before connecting to the burner. **Note that no soldered joints are permissible in the oil line.**

4:8.1 Oil Filter

An Oil Filter is provided with the Heater. Connections are ¼ BSP Female, see Fig. 4:8b, 4:8c, 4:8d, 4:8e, 4:8f, 4:8g.

It is essential for reliable operation that the Oil Filter is fitted in the Oil Pipe supplying Oil from the Tank to the Burner. **It is a condition of the guarantee that the Filter is fitted correctly.**

4:8.2 Fire Check Valve (Not Supplied)

A 90°C Fire Valve must be fitted in the suction line see BS 5410: Part 1.

The valve must be fitted external to the Heater, pref-

erably at point where the Oil Pipe enters the building. The sensor should be located above the Burner in the clip provided, see Figs. 4:8a, 4:8b, 4:8d & 4:8f.

The entry point for the Fire Valve Sensor is shown on Fig. 4:8a & Fig 7:2c.

To ensure the casing seal is maintained, always pass the Sensor through the blind grommet (supplied), it will be necessary to cut across the diaphragm.

4:8.3 Single Pipe System Fig. 4:8b

If the bottom of the Oil Tank is above the Burner, install a 10mm copper supply pipe to the Burner incorporating the correct Filter, Shut Off Valve and Fire Check Valve.

Ensure that the Burner Oil Pump is correctly set for 'Single Pipe' operation. (See section 4:8.2)

4:8.4 Two Pipe System Fig. 4:8d

When the bottom of the Oil Tank is below the level of the Oil Pump on the Burner it is necessary to install an additional 10 mm return pipe.

The Oil Filter, Shut Off Valve, spring loaded Non-Return Valve and Fire Check Valve are always in the suction line supplying oil from the Tank to the Burner.

The Non-Return Valve must be fitted to allow the flow in the correct direction and prevent drain back to the Tank, see Fig. 4:8e.

Ensure that Valves are NOT fitted in the Return Line. The Return Line must be unobstructed at all times.

Ensure that the Burner Oil Pump is correctly set for 'Two Pipe' operation. (See section 4:8.1)

4:8.5 Deaerator Oil Pipe System Fig. 4:8f

An alternative two pipe arrangement can be achieved using a 3K Oil Loop Deaerator which removes the air from the oil feed on a single pipe lift. The Burner Pump is piped to the Deaerator, which should be positioned close to the burner, but NOT inside the Heater Case.

A Non-Return Valve is not required in the return line.

The advantage of this system is gained where a two pipe run from the oil supply tank is long or difficult to achieve.

3K Deaerators are available as an optional extra from your merchant (Part No. BS 03060).

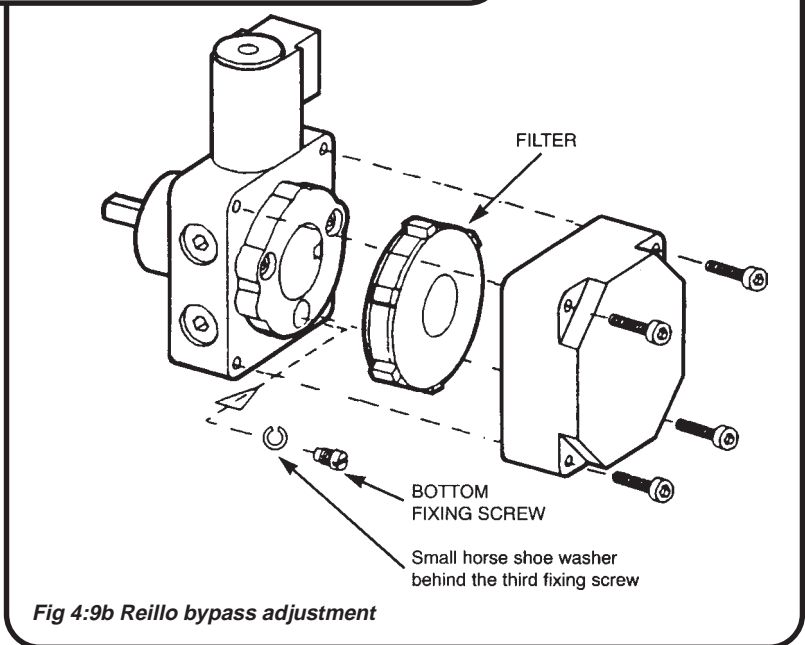
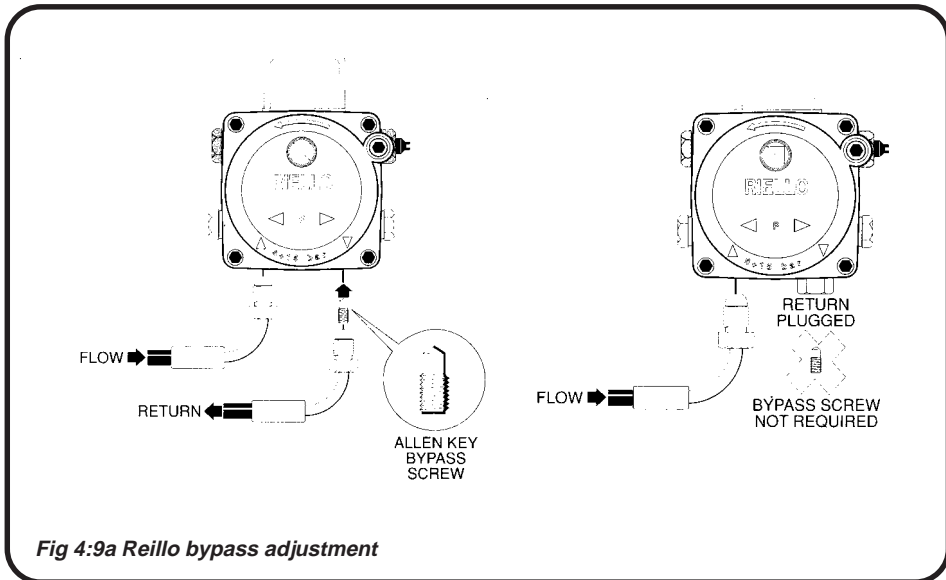
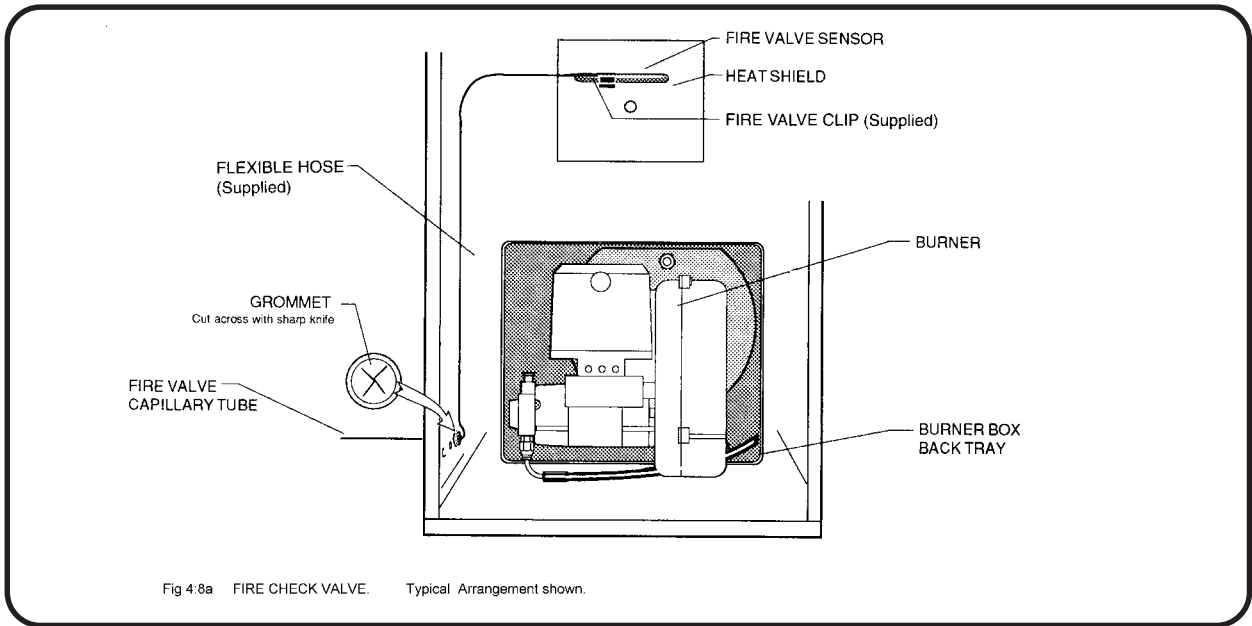

4:7.6 Water Separator Oil Filter

A Water Separator For Gas Oil is recommended (part No. BS03052).

4:7.7 Flexible Oil Pipes

The Flexible Oil Pipe is fitted inside the Heater casing and is of adequate length to enable the Burner to be removed without disconnecting.

4:8 OIL BURNER

The Burner manufacturers' Technical Leaflet is supplied with this manual and provides supplementary information not included in this manual.

4:8.1 Burner Pump for Two Pipe System

For two pipe oil systems the Burner Oil Pump has to be fitted with the Bypass Screw supplied. Heaters are despatched with the Bypass Screw in a labelled envelope attached to the Burner. This socket screw

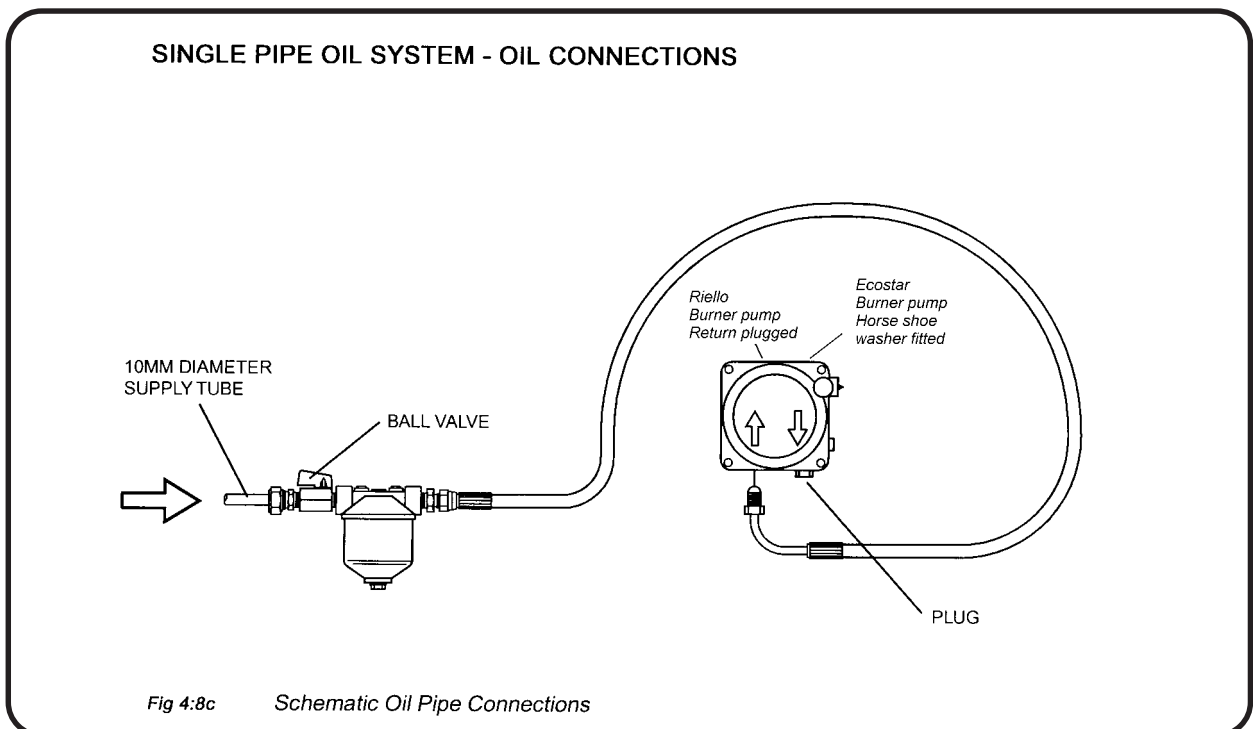
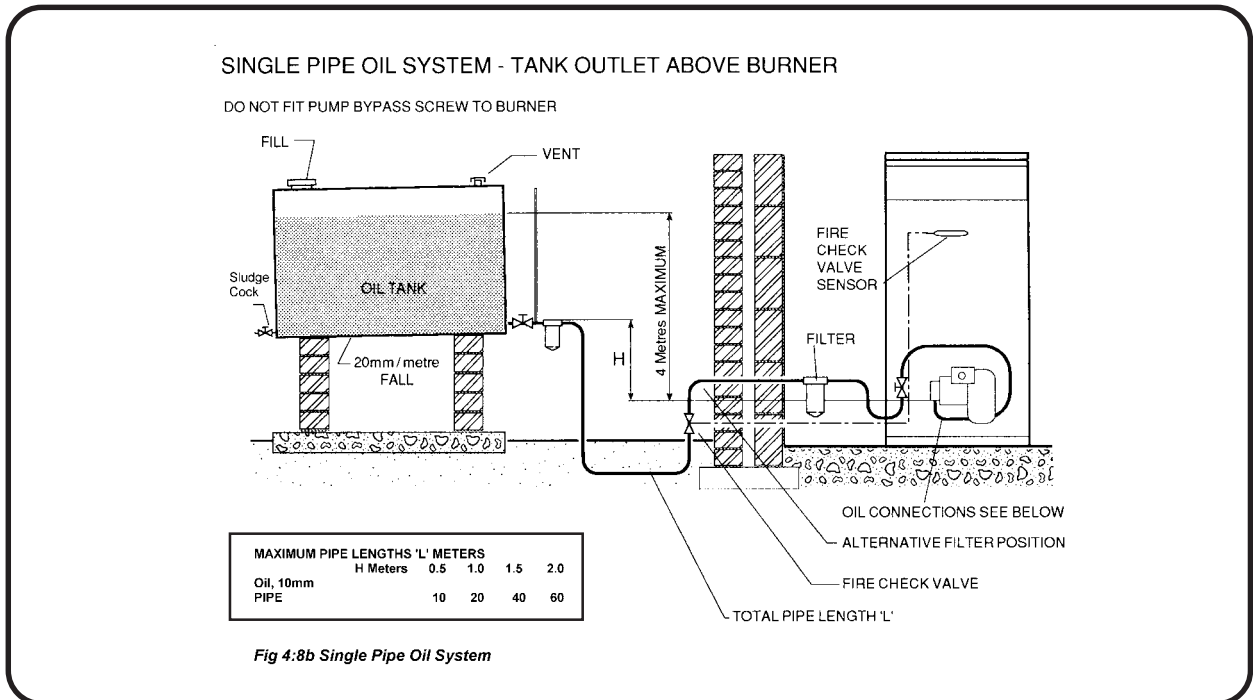

is inserted into the return port as shown in Fig. 4:9a.

ONLY USE SUPPLIED BYPASS SCREW FOR ALLEN KEY (2.5mm). DO NOT USE SLOTTED SCREW TYPE.

4:8.2 Burner Pump for Single Pipe System

The burners are supplied set for single pipe operation. On the Reillo burner the return port is plugged and the Bypass Screw is not fitted. See Fig. 4:9a.

4:9 SENSOR POSITIONS

The Heater Control Temperature Sensor fits into the right hand pocket on the top of the Heater Heat Exchanger.

The Limit Stat 8mm Coiled Phial fits into the second pocket on the left hand side on the top of the Heater Heat Exchanger.

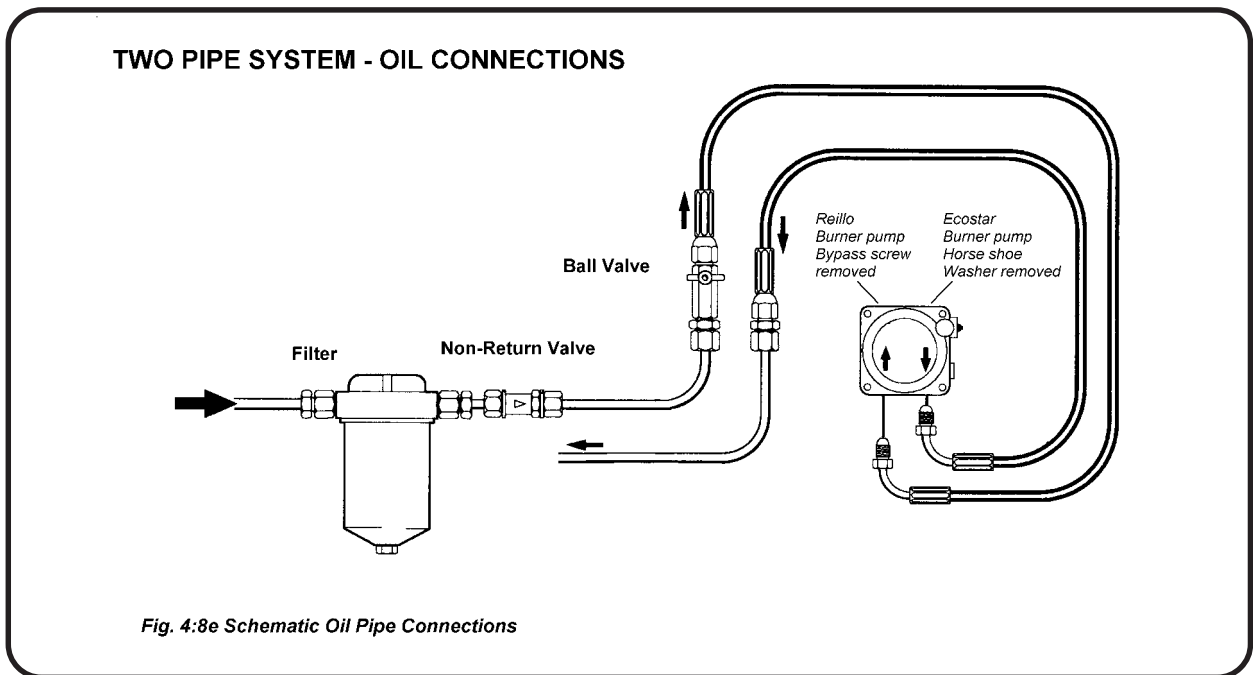
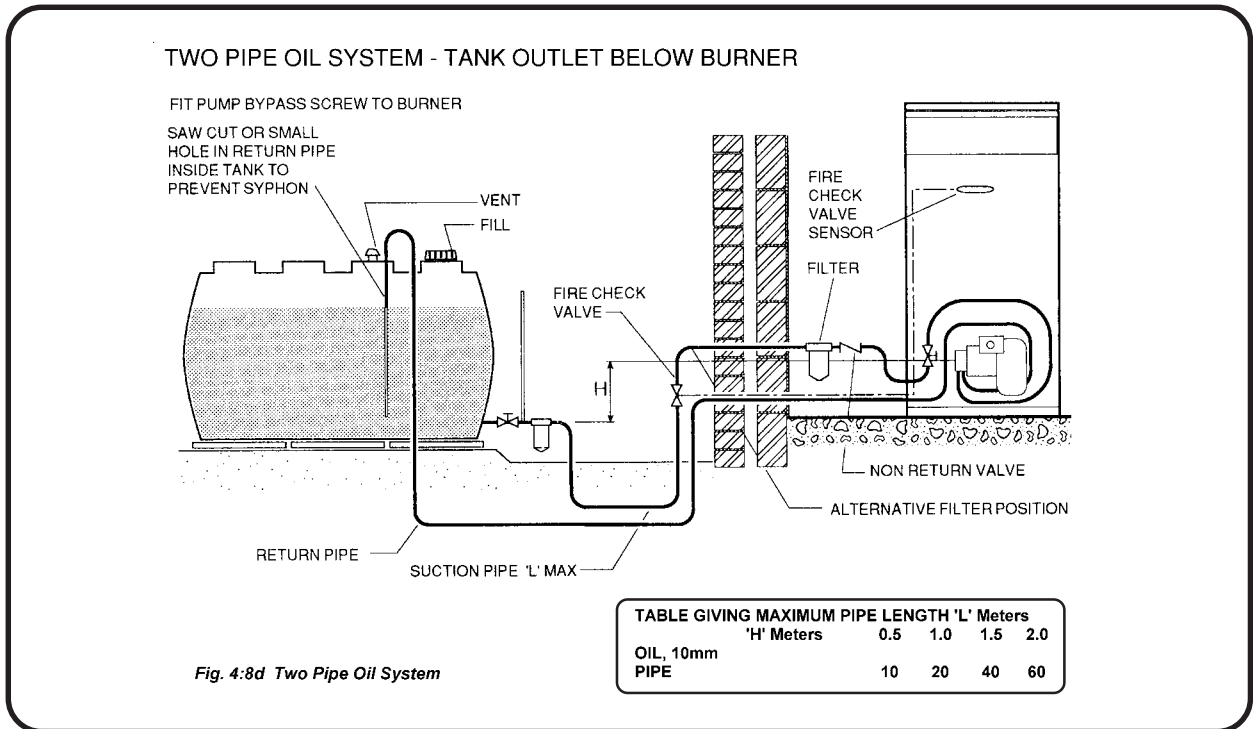

DEARATOR OIL SYSTEM - TANK OUTLET BELOW BURNER

FIT PUMP BYPASS SCREW TO BURNER

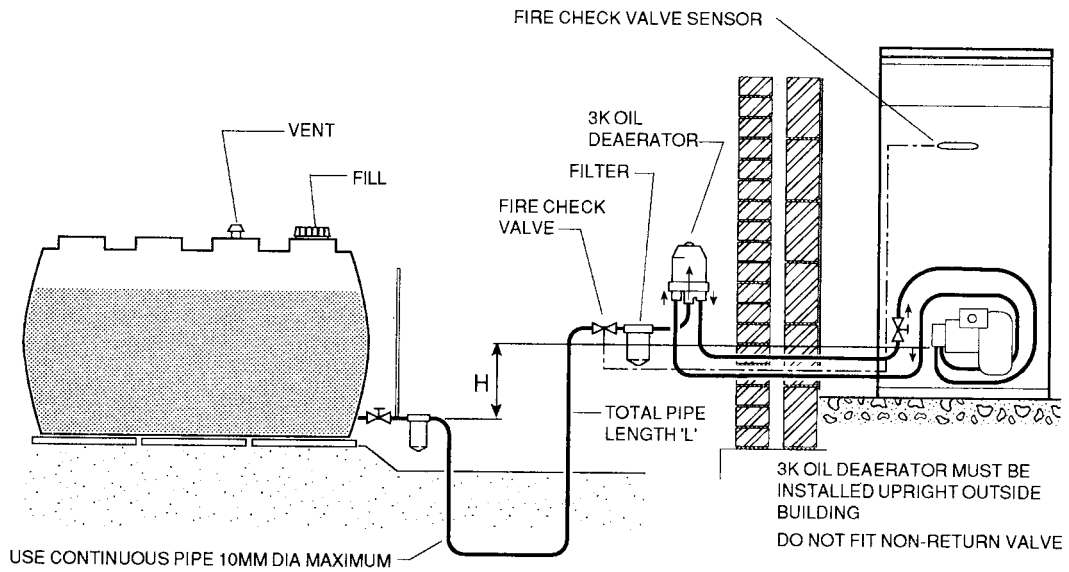

USE CONTINUOUS PIPE 10MM DIA MAXIMUM

The table right shows total Pipe Length 'L' metres.

Note: RIELLO 40 Burner Types are listed assuming maximum Oil Rate.

Oil Rate	Lift 'H' Meters (3.5m Max)							
10mm Pipe	0	0.5	1.0	1.5	2.0	2.5	3.0	3.5
	100	100	100	100	98	87	75	54

Fig. 4:8f Deaerator Oil System

DEAERATOR OIL SYSTEM - OIL CONNECTIONS

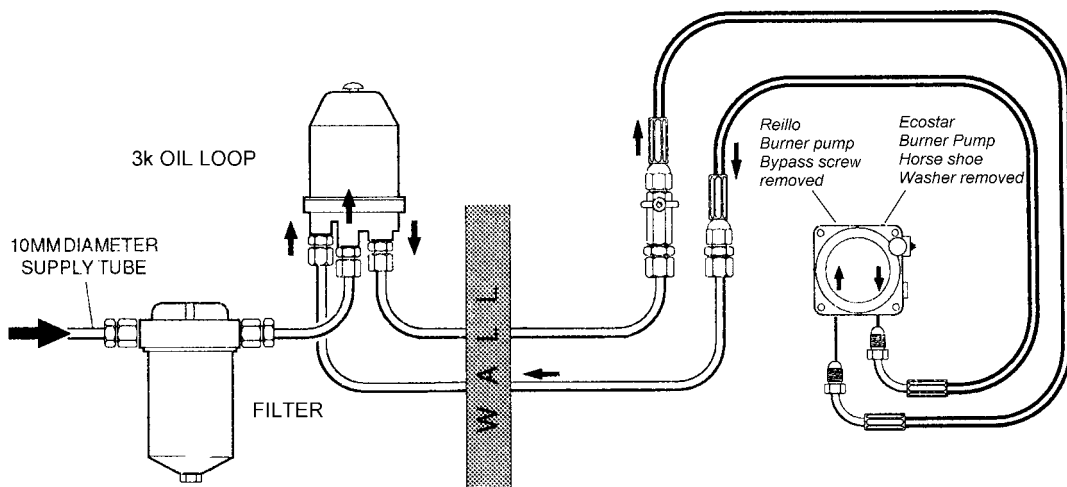
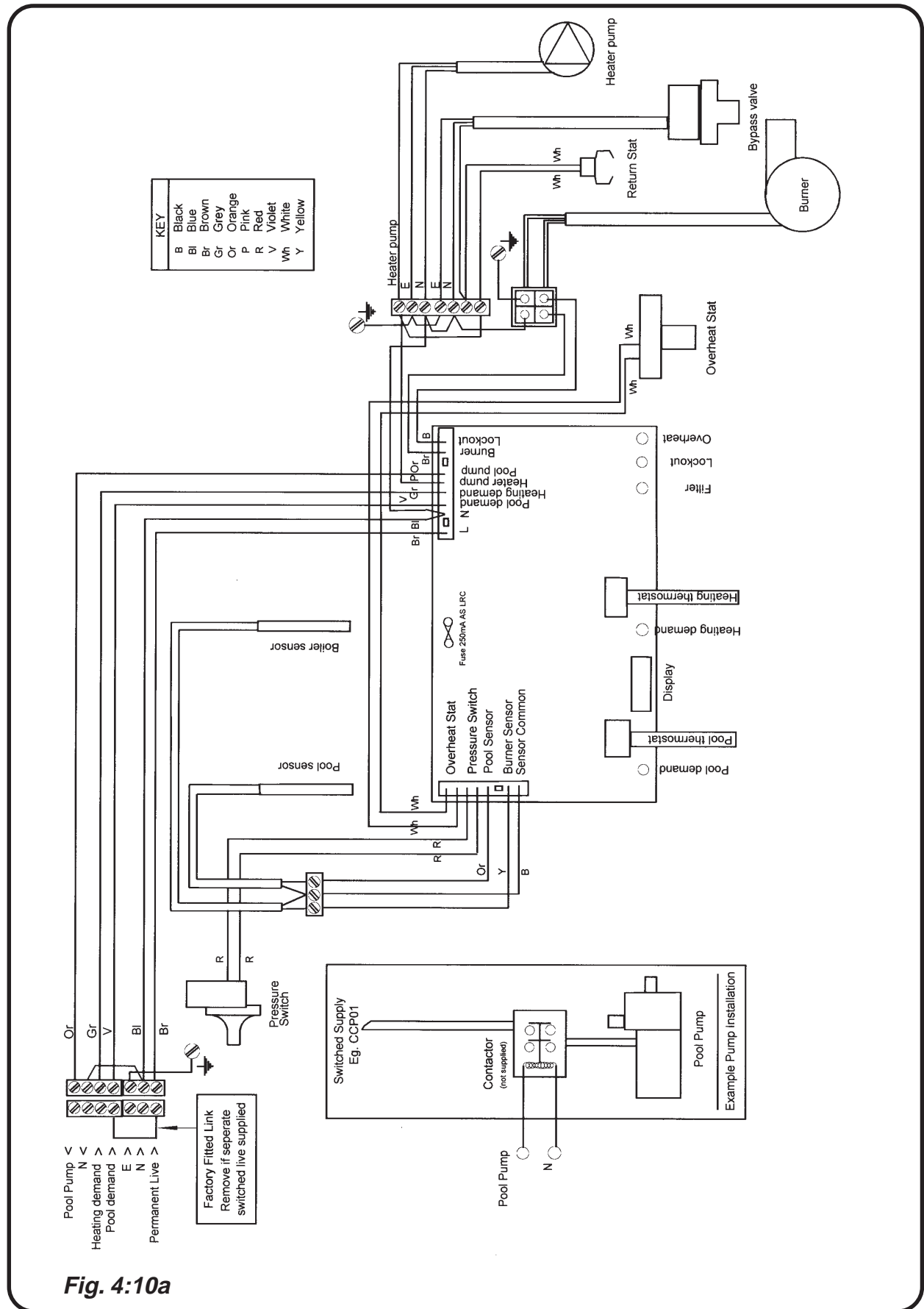

Fig. 4:8g Schematic Oil Pipe Connections

4:10 WIRING DIAGRAM
SCHEMATIC WIRING



5: FLUES

5:1 CONVENTIONAL FLUE (FLUE 4" 5" OR 6")

CONVENTIONAL FLUE INSTALLATION ONLY.
FOR BALANCED FLUE INSTALLATIONS SEE SECTION 5:3

The Heater requires a minimum stable draught of 0.1 mbar (0.04w.g.).

If the chimney exceeds 6m (20 feet) in length, it may produce a draught exceeding 0.37 mbar (0.15" w.g.) and a draught stabiliser should be fitted.

The chimney should comply with the latest edition of the Building Regulations and BS5410: Part 1. Factory built chimneys must comply with the Building Regulations and BS 4543 Parts 1 and 3.

Compliance with the Building Regulations does not indicate that the chimney is satisfactory in respect of draught conditions, or is positioned so that 'down draughts' will not occur.

Special pots and cowls which might restrict the flow of gases must not be fitted and should be removed.

A brick chimney must be fitted with a suitable stainless steel liner. Insulation between the liner and an exposed chimney may be necessary to avoid condensation.

A flexible liner should be the same diameter as the Flue Offtake size of the Heater - 4"(100 mm), 5" (125 mm) or 6" (150mm).

The Flue pipe, connecting the Heater to the chimney should be the same diameter as the Heater Flue Offtake and should not be more than 1.8m (6'-0") long. Flue Pipes when fitted should satisfy or be deemed to satisfy the Building Regulations.

Flue pipe bends - 90° bends should be avoided use 135° bends. Bends with soot doors should be used where necessary.

5:2 AIR SUPPLY

CONVENTIONAL FLUE INSTALLATION ONLY
IMPORTANT

A permanent adequate supply of air is required for combustion and correct operation of a draught stabiliser, if fitted.

This air enters the Heater at the rear. It must never be blocked off. At least 25 mm clearance is required at the rear for all models.

When the Heater is situated in a confined space or chamber a permanent adequate supply of air is required for ventilation to prevent over heating.

5:2.1 Opening Sizes

The clear opening required for combustion only should be based on a requirement of 550 mm²/kW, (or 1in² per 4000 Btu/h).

When a draught stabilizer is fitted to the flue pipe or chimney in the room in which the Heater is situated the clear air intake should be 1100 mm²/ kW, (or 2in² per 4000 Btu/h).

When the Heater is situated in a confined space with Combustion or Ventilation air from outside Allow 550 mm²/kW, (or 1in² per 4000 Btu/h) at low level and in addition 550 mm²/kW. (or 1in² per 4000 Btu/h) at high level;

When Combustion and Ventilation air is taken from a heated adjoining space the allowance should be 1100 mm²/kW, (or 2in² per 4000 Btu/h) at low level and in addition 1100 mm²/kW, (or 2in² per 4000 Btu/h) at high level. Ensure that the heated adjoining space itself has an adequate supply of air.

When the Heater is installed in a basement or at low level where air can enter only from high level, the incoming air supply for Combustion and Ventilation should be ducted to low level. A high level outlet should be provided for ventilation.

If the Heater is installed in a room with an extractor fan the combustion performance must not be affected when the fan is running with all doors and windows closed.

5:3 BALANCED FLUE HEATERS

Balanced Rear Flue Kits are available as optional extras for each model. All models can be flued, at low level, side or rear, and vertically to 6 metres.

Balanced Flues permit considerable choice of siting of the Heater. Heaters may be installed in situations where no chimney exists, where the existing chimney is unsatisfactory or in outhouses.

Please note, because of pipe connections for the Pool it may be necessary to choose a longer than Standard flue length for Left Hand flues.

It is important that care is exercised in choosing a suitable location for the Heater and Flues.

It is a mandatory requirement that:

1. Low level balanced flues are not used for Heaters operating with gas oil (Class D fuel).
2. The terminals of balanced flues which can be touched are to be fitted with a guard.

It is not permissible to burn Gas Oil (Class D) fuel if a LOW LEVEL HORIZONTAL balanced flue is to be used.

5:4 BALANCED FLUE TERMINALS

The Terminals of Horizontal Balanced Flues should be installed on a plain surface of wall preferably not less than 900mm from internal corners of the building and away from any recesses and any projections on the wall face that could affect wind flow across it. It is fixed to the outside wall with a loose Flange that is secured with four screws.

Listed are general restrictions as to the positioning of Horizontal Balanced Flue Terminals. **Refer to Fig. 5:4a**

1. Positions should be avoided where the exhaust of combustion products could cause nuisance.
2. Terminals must be situated more than 600mm distance from any opening in the building.
3. Close proximity to internal corners where products of combustion may not freely disperse and may enter the air intake to the Heater.
4. Positions such as narrow passageways, especially with a closed end, where easy dispersion could be adversely affected.
5. Positions where the terminal maybe discharging close to and in the direction of a near neighbouring dwelling or exhausting immediately over adjoining property.

6. Position immediately under openable windows.
7. Care should be taken to ensure that there is clearance between the outer surface of the flue and any combustible material.
8. Positioning the Flue Terminal within a CAR PORT is not recommended.

5:5 TERMINAL GUARDS

When the terminal is positioned where there is the possibility of accidental contact by persons, or of damage to the terminal, an approved guard is necessary (Code SPCOHTG1 / SPCOHTG2)

Generally, exhaust 2 metres above ground level alleviates the necessity for a guard.

5:6 POSITIONING THE HEATER

Read Section 5:4

Some combustion noise occurs at the Terminal of Balanced Flues and care should be exercised to ensure that the position is not near doors or opening windows of the house it serves, or doors or windows of any neighbouring house.

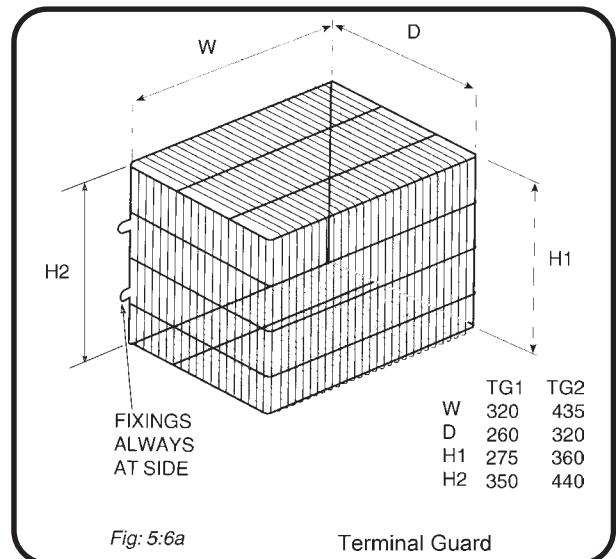

Fig. 5:4a Balanced Flue Terminal Positions

RECOMMENDED FLUE TERMINAL POSITION

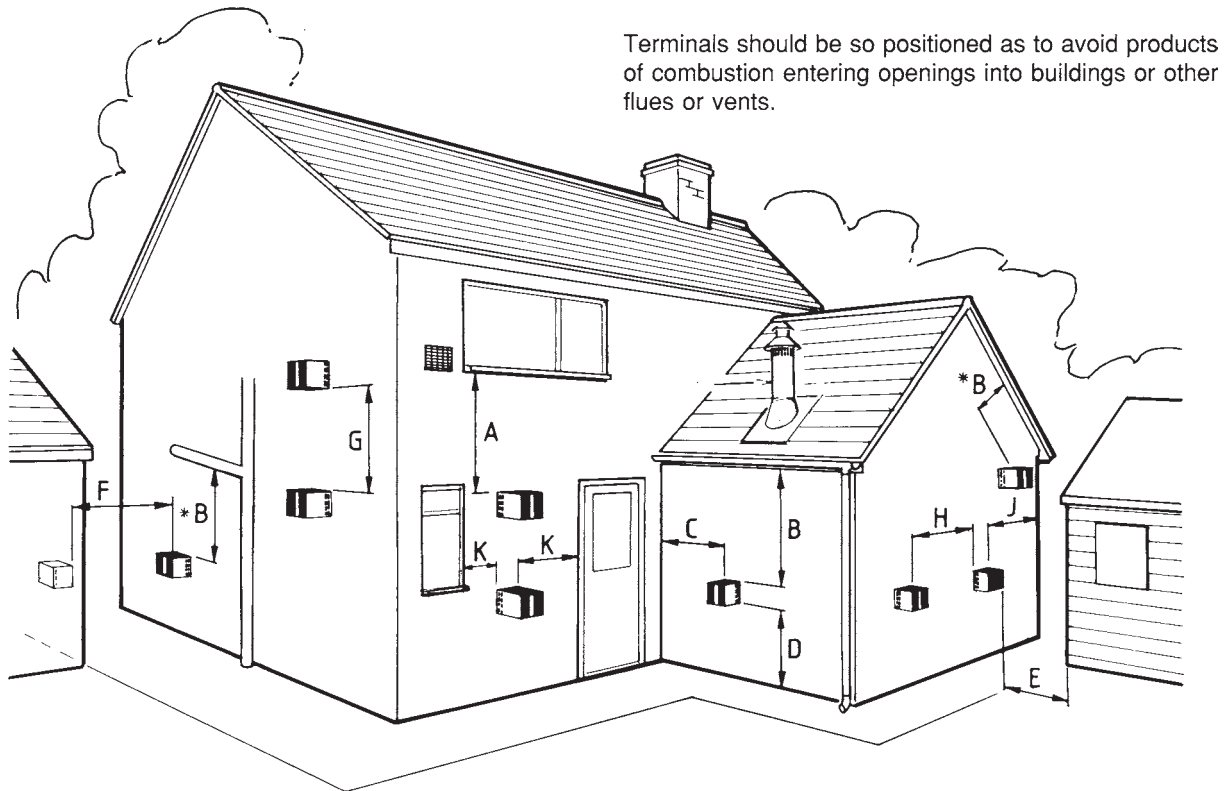

Table to above Flue Terminal Positions - MINIMUM dimensions

REF	DESCRIPTION	DISTANCE IN mm
A	Directly below an Opening, Air Brick or Window	600
B	Below a Gutter, Sanitary Pipework or Eaves	600*
C	From an Internal Corner	900
D	Above Ground	700
E	From a surface facing a Terminal	2000
F	From a Terminal facing a Terminal	2000
G	Vertically between Two Terminals on the same wall	1500
H	Horizontally between Two Terminals on the same wall	1200
J	From an External Corner	600
K	Horizontally from an Opening, Air Brick, Window or Door	600
	Horizontally from Outdoor Terminal	600
	Above an Outdoor Terminal	3000

* Where the Terminal is within 1m of any plastic material, such material should be shielded from the effects of the combustion products of the flues.

The Flue Terminal positions given are as recommended by the Manufacturer. The final position of the flue should be checked with the local Building Inspectorate.

6: BALANCED FLUE INSTALLATION

6:1 GENERAL INFORMATION

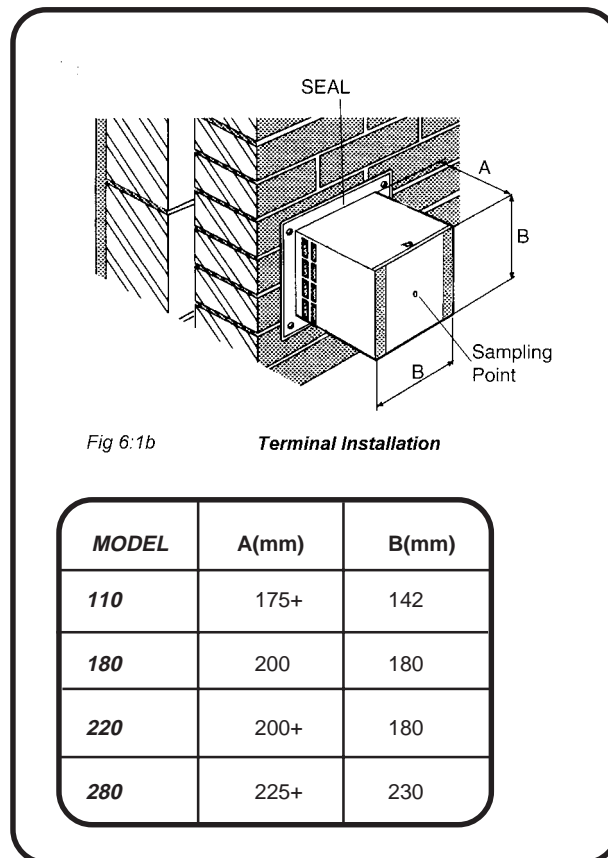
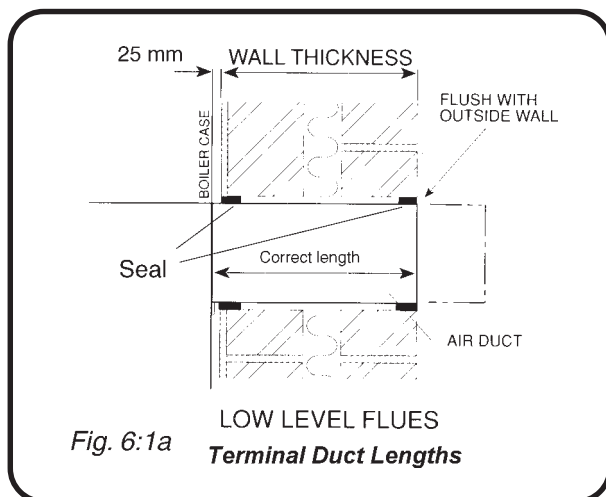

MODEL	A(mm)	B(mm)
110	175+	142
180	200	180
220	200+	180
280	225+	230

6:2 HORIZONTAL BALANCED FLUE INSTALLATION

6:2.1 Model 110, 180 and 220 Only

Read these instructions before assembling the flue. Site Conditions will dictate the best method.

Assembly

1. Mark Flue Position, (See Fig. 6:2a), and knock out hole in the wall with 10mm clearance.
2. Remove both Top Panels.
3. Replace the four screws in the Rear Top Panel with the Blanking Plate supplied.
4. If side flued, remove the appropriate Flue Blanking Plate and move to the rear.
5. Place the Centralising Ring in position in the Heater.
6. Measure the distance from the outside wallface to the heater side/rear panel, L.
7. Assemble the Terminal and Air Duct, the Terminal slots vertical and the larger flange down, to achieve the overall dimension of L+C. (See 6:1b and Fig6:2a) then tape the joint.

Preferred method, flue assembled to boiler away from wall.

8. It is recommended that a trial fitting the Flue Elbow is now made.
9. Apply the supplied Silicone Sealant as a generous bead to the outside of the long end of the Flue Elbow and slide it into the Terminal Assembly.
10. Fit the Flue Elbow to the Centralising Ring and secure the complete Flue Assembly to the Heater with the four nuts and washers supplied.
11. Move the Heater into position.
12. Caulk in the flue to the Flue Ring with the Fire Cement and Rope supplied.

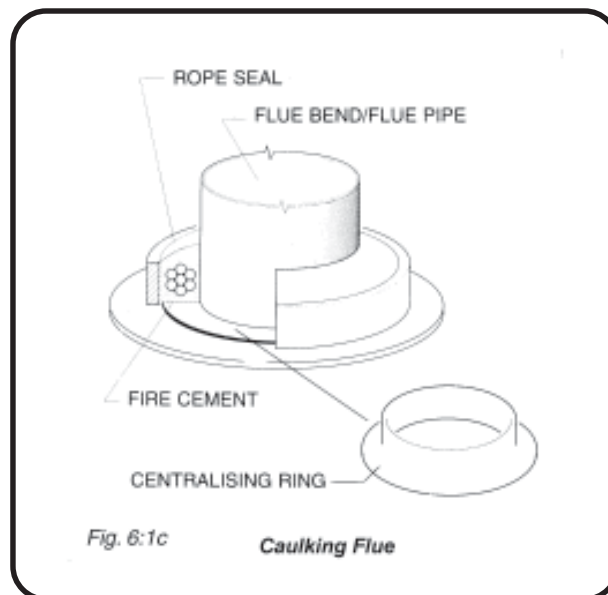

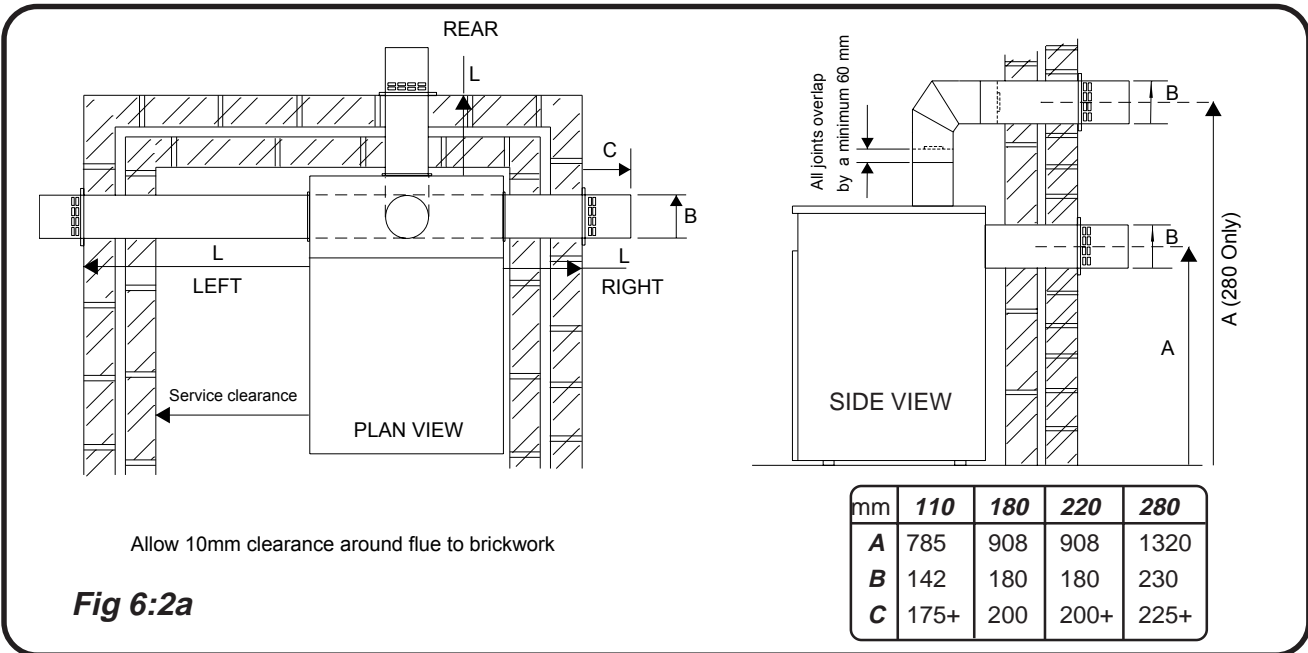

Fig 6:2a

Model	L, Length range mm			Part No	Description
	Rear	Right	Left		
110	254 - 457	254 - 457	X	SPCOHBF1	Standard 110 Balanced Flue
110	457 - 864	457 - 864	500 - 864	SPCOHBF1L	Long 110 Balanced Flue
180 & 220	254 - 457	254 - 457	X	SPCOHBF2	Standard 180/220 Balanced Flue
180 & 220	457 - 864	457 - 864	500 - 864	SPCOHBF2L	Long 180/220 Balanced Flue
280	214 - 414	110 - 310	X	SPCOHBF3	280 Standard Flue
280	674 - 874	570 - 770	1175 - 1375	Plus SPCOHBVF25E	280 Short Extension
280	1084 - 1284	980 - 1180	1585 - 1785	Plus SPCOHBVF21E	280 Long Extension

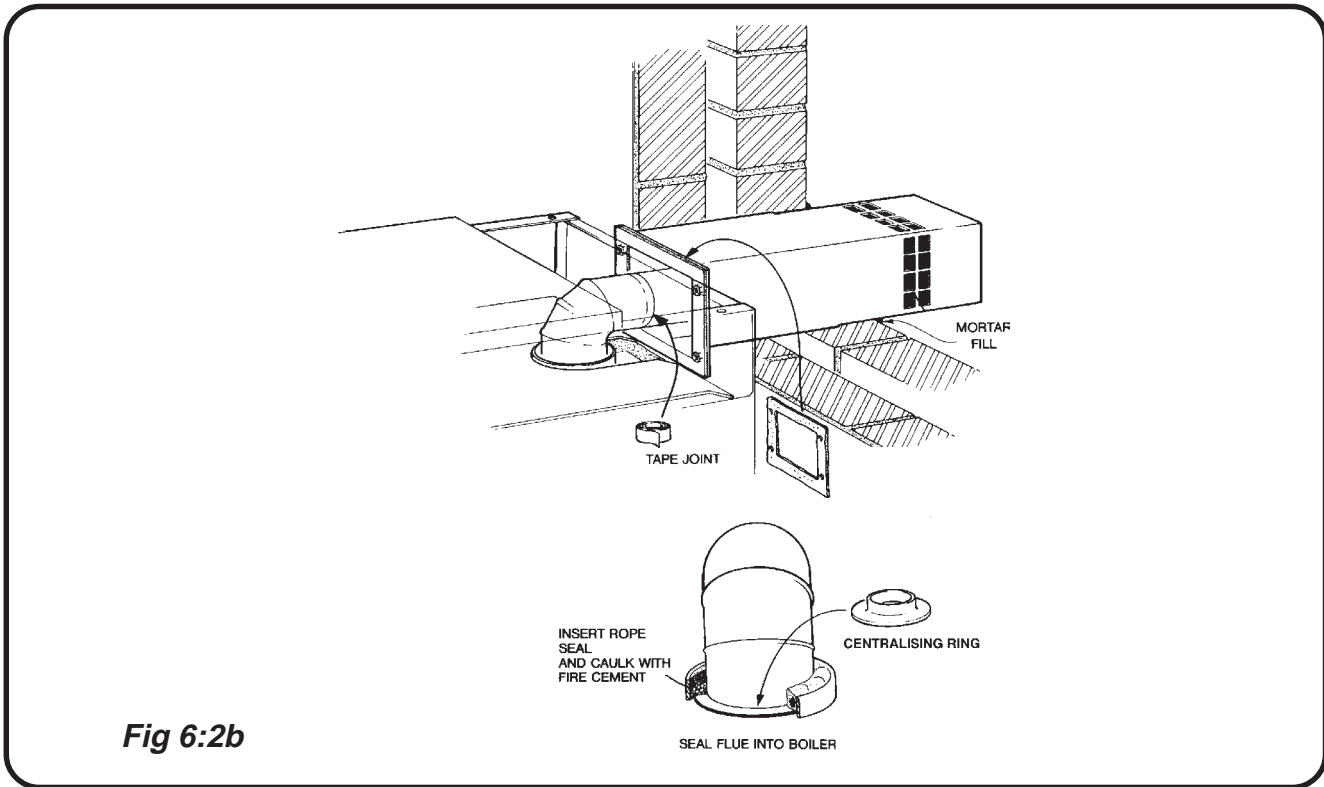

Fig 6:2b

13. Seal to the wall around the Air Duct using silicone sealant.

Alternative Method, with Heater in position. Not recommended for Rear Flue

8. Slide Terminal Assembly into the wall with the Terminal slots vertical.
9. Position the Heater.
10. It is recommended that a trial fitting the Flue Elbow is now made.
11. When satisfactory, apply the supplied Silicone Sealant as a generous bead to the outside of the long end of the Flue Elbow and from the inside of the Heater, fit the Flue Elbow to the Terminal Assembly and Centralising Ring.
12. Secure Air Duct to the Heater with the four nuts and washers supplied.
13. Caulk in the flue to the Flue Ring with the Fire Cement and Rope supplied.
14. Seal to the wall around the Air Duct using silicone sealant.

6:2.4 Model 280 Only

Longer 280 Balanced Flues are obtained by adding one of two extensions to the Standard Flue.

Assembly

1. Position the boiler and check that all the water connections and proposed flue position are according to the clearances specified.
2. Mark the flue position on the wall.
3. Move the boiler away from the wall and drill or knock out an 8" (200 mm) level hole.
4. Remove the top panels of the boiler and the C shaped Trim piece from the Rear Top Panel.
5. Remove the Conventional Flue Adapter.
6. Re-use the existing gasket, foil side uppermost with the Vertical Flue Adapter
7. Secure to the Heater with the four nuts and washers previously removed.
8. Fit the Rear Top Panel over the flue adapter.
9. Ensure the flue exhaust seal is in position and undamaged. Lubricate with detergent.

If an extension is being added.

10. Take the next section, lubricate the sealing ring with detergent and ensure that the flue exhaust seal is fitted to the inner duct undamaged and in the correct orientation.
11. With seals fitted, slide the sections together, internal sealing ring end first.

For a horizontal section.

12. Take the Elbow section and fit a small sealing ring to each end. Lubricate with detergent and ensure that the flue exhaust seal is fitted to the inner duct undamaged and in the correct orientation. The Elbow should slope slightly down to the outside.
13. For the section passing through the wall, check there is no debris that might be picked up by it before sliding it through. It should slope slightly down to the outside.
14. Secure each joint by drilling and holding with two self tapping screws.

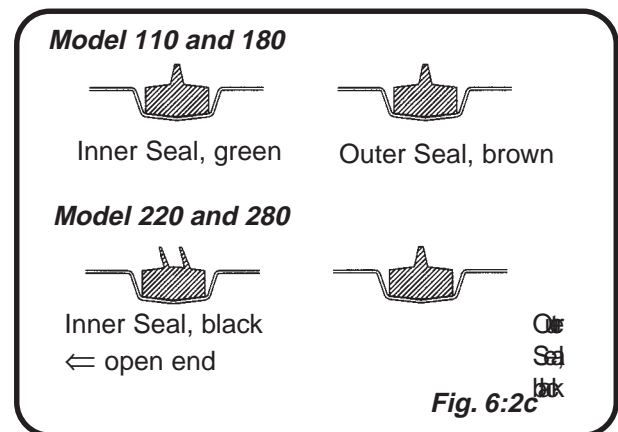

From the outside

1. Remove the outer terminal four screws and put to one side.
2. Check all seals are fitted and in good condition.
3. Check the cavity is clear before sliding the outer Air Duct into the inner Air Duct.
4. Using the four holes in the Outer Wallplate as a guide, drill four fixing holes to suit the supplied screws.
5. Secure the Outer Wallplate, weather sealing all edges.
6. Offer up the Terminal square to the wall and push home onto the internal Flue Duct until the four holes align. NOTE: Ensure TOP is uppermost.
7. Secure the Terminal to the Wallplate with four screws.
8. Where required fit an approved Terminal Guard.

In the Heater

1. Use the clips supplied to fix the Snorkel to the Burner and the Flue Adapter.
2. Replace the Front Top Panel.

6:3 VERTICAL BALANCED FLUE

All Models

Maximum floor to Rain Cap height is 6000 mm.

Model	Adjustment	Flue Kit	Short Extension	Long Extension
110	590	SPCOHBFIV1	SPCOHBFV15E (500 mm)	SPCOHBFV11E (1000 mm)
180	730	SPCOHBFIV1	SPCOHBFV15E (500 mm)	SPCOHBFV11E (1000 mm)
220	740	SPCOHBFIV2	SPCOHBFV25E (460 mm)	SPCOHBFV21E (870 mm)
280	810	SPCOHBFIV3	SPCOHBFV25E (460 mm)	SPCOHBFV21E (870 mm)

- Check the Flue lengths make the required height. Measure the height from the floor to the outside of the roof (H). Subtract the **Adjustment** figure in the Table above, this takes into account all other dimensions including the 600mm required above the roof. The length of Extensions must be equal or greater than this figure. Example for a Model 110. $H = 3000\text{mm}$; Extension Length = $3000 - 590 = 2410 = 2 \times \text{SPCOHBFV11E} + 1 \times \text{SPCOHBFV15E}$
- Remove the top panels of the boiler.
- For the 280 only.**
- Remove the CF Flue Adapter and re-use the existing gasket, foil side uppermost to fit the BF Adapter then connect the Snorkle Tube.
- Remove the C shaped Trim from the Rear Top Panel, and discard then re-fit the Rear Top Panel.
- For the 180 Only.**
- Place the Centralising Ring in the heater Flue Ring
- For all models except the 280.**
- Fit the flue adapter to Rear Top Panel, and secure on the four studs with nuts and washers provided.
- Place the U/L Adapter Pipe in the Flue Ring, lubricate the seal ring then refit the Rear Top Panel Assembly.
Caulk in the flue with Fire Cement and Rope provided.
- All Models**
- Fit the Back Panel Infill Plate.
- Place the optional Ceiling Trim over the flue.
- Position the boiler and check that all the water connections and proposed flue position are according to the clearances specified.
- Take the next section and ensure that the correct seals are fitted and undamaged and lubricated. **See Fig. 6:2c.** Then slide the sections together, internal sealing ring end first.
- Secure each joint with a minimum 60mm overlap by drilling with drill provided and using two self-tapping screws.
- Build up to the required height to reach the Roof Terminal and complete as shown in **Figs. 6:3a and b**
- Fit the Flashing Plate and Cravat, keeping the cravat as low as possible. Seal with RTV sealant provided.
- Refit Front Top Panel.

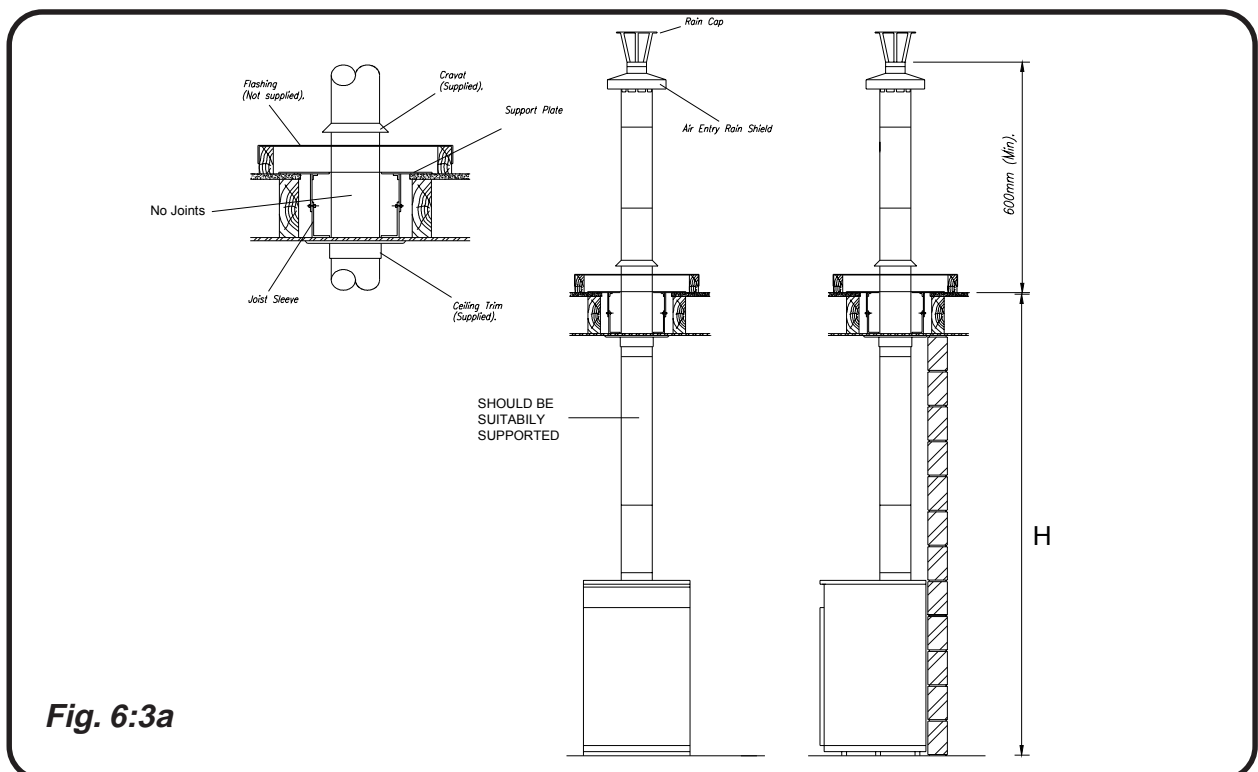

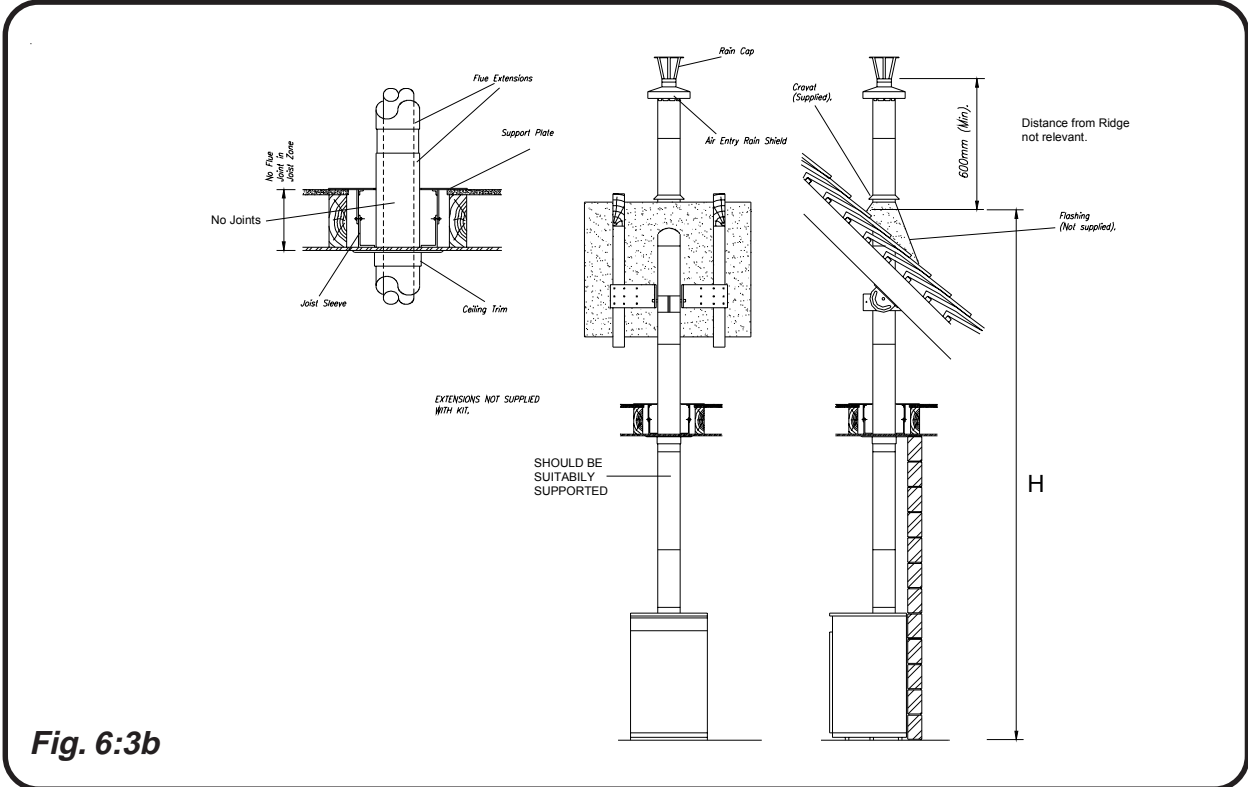

Fig. 6:3b

6:4 OUTDOOR FLUE KITS

The kits are to convert the range of Oil Fired Pool Heaters into free standing Outdoor Oil Pool Heaters.

There are three kits available, please ensure you have the correct conversion kit for your Heater by consulting the table below.

Model	Kit Number
110	SPCOHBFOV10
180	SPCOHBFOV11
220	SPCOHBFOV11
280	SPCOHBFOV3

IMPORTANT: ENSURE POWER SUPPLY CONFORMS TO I.E.E. REGULATIONS AND ANY LOCAL REGULATIONS WHICH APPLY.

All Models

Installation Instructions

1. Position Heater. Avoid products of combustion causing a nuisance or entering openings into buildings or other flues/vents
2. Lift off the Front Top Panel.
3. Remove the two screws retaining the Rear Top Panel to the Side Panels and retain.
4. Remove the Rear Top Panel, remove and discard the four screws in it.
5. **For the 110, 180, 220:** Fit the Flue Spigot into the Heater Flue Ring and caulk in with the rope and cement provided with the Heater.
6. **For the 280.** Fit the CF Flue Adapter with the four nuts provided, ensuring the gasket is between the Adapter and the Heater.
7. Fit the Rear Top Panel into position and secure with the two retained screws into the Side Panels.
8. Fit the Base to the Rear Top Panel and fix with four Nuts and Bolts (110/180/220) or Screws (280).
9. Secure the Base to the Heater Back Panel with the one Screw provided. (It may be necessary on some models to drill a 1/8" hole.)
10. Assemble the Top to its Base with the three screws provided.
11. Refit the Front Top Panel.
12. Where provided in the kit, fit the four fixing Tabs, or the alternative of a single securing screw at the bottom of the door and the retaining bracket on the front of the Flue Top.

See Fig 6:4a

Fixing Tab Locations

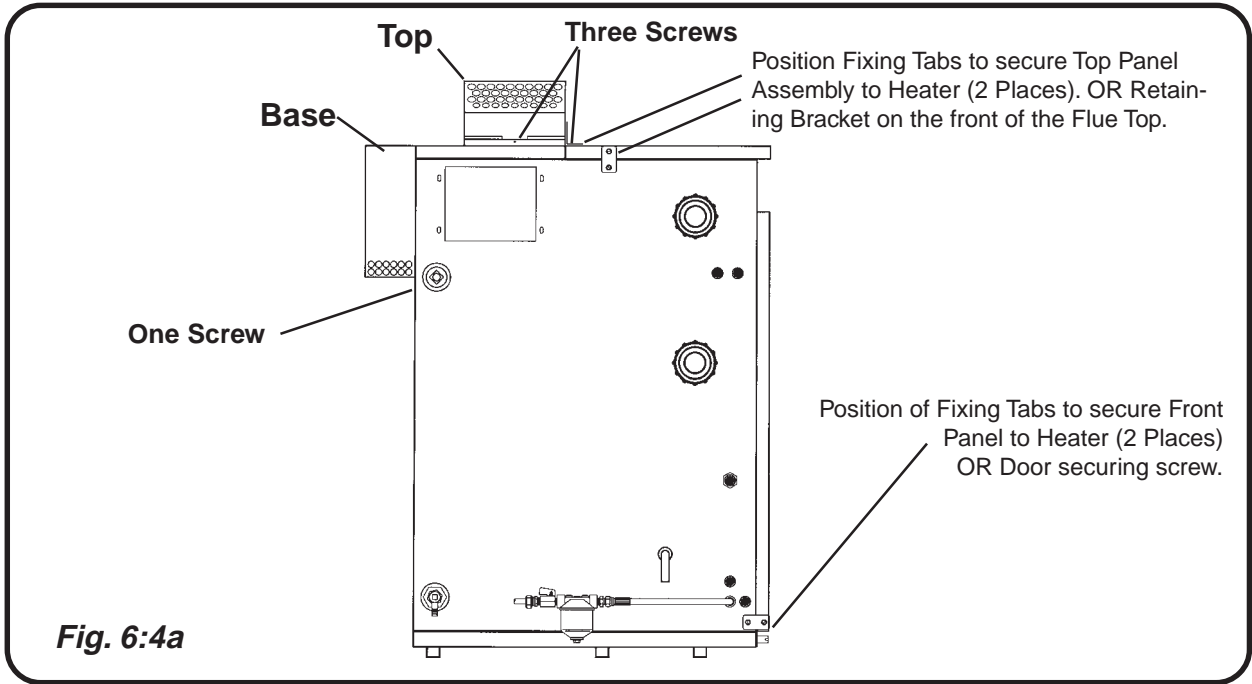

Fig. 6:4a

General Location of Components

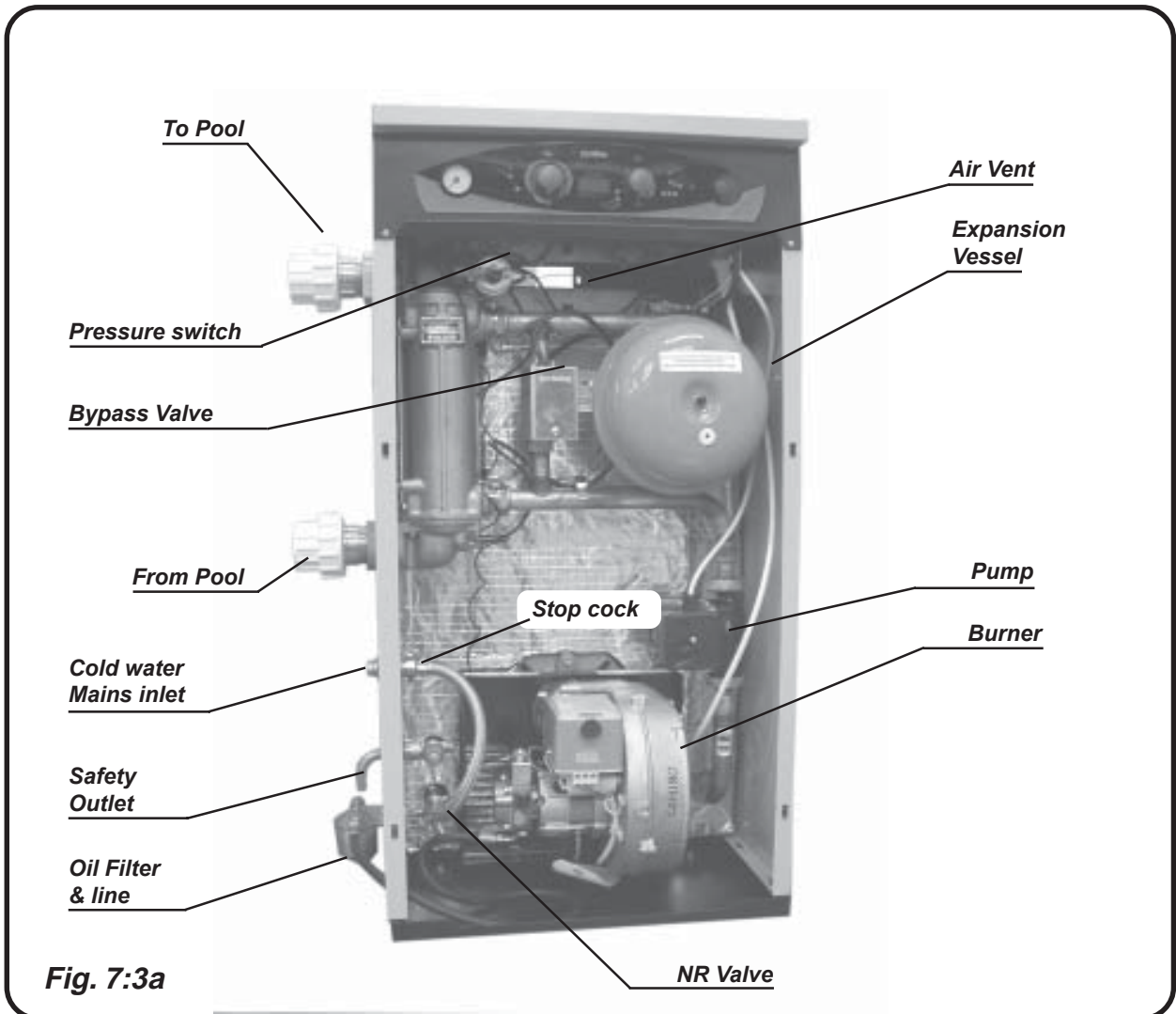

Fig. 7:3a

7: COMMISSIONING

7:1 GENERAL INFORMATION

It is essential in the interest of Heater efficiency and reliable performance that once the Heater has been installed it is first commissioned by a qualified OFTEC engineer.

If an engineer is not known the Manufacturer will be pleased to provide details of an approved commissioning and servicing engineer from their list of OFTEC approved engineers.

7:2 FILLING THE HEATER

The Manufacturer requires that the Heater is always flushed before filling and an appropriate Inhibitor is used. The following filling procedure is recommended.

1. Due to movement in transit some factory made joints may require remaking or tightening after installation.
2. Fill using the filling loop provided and inspect for leaks on all the joints inside the heater.

3. Empty the Heater to flush clean, then close the drain point.
4. Add the inhibitor provided by unscrewing the Air Vent on the Rear Flow boss and carefully pouring in.
5. Refit the Air Vent.
6. Refill the Heater to 1 bar, then, after turning off both valves on the filling loop, disconnect the filling loop from one end.
7. With the Oil supply turned off, power up the Heater with a call for heat so that the internal pump runs. See 3:5 for pump speed setting
8. Stop pump by turning off the supply so as to let air settle, then vent.
9. Repeat steps 7 and 8 until no more air can be heard or vented.
10. Check that all three Sensors are fully in to their respective pockets.
11. Turn off both valves on the filling loop and if permanently connected to the Mains, disconnect at one end.
12. Turn on the oil supply.

HYDRAULIC SCHEMATIC

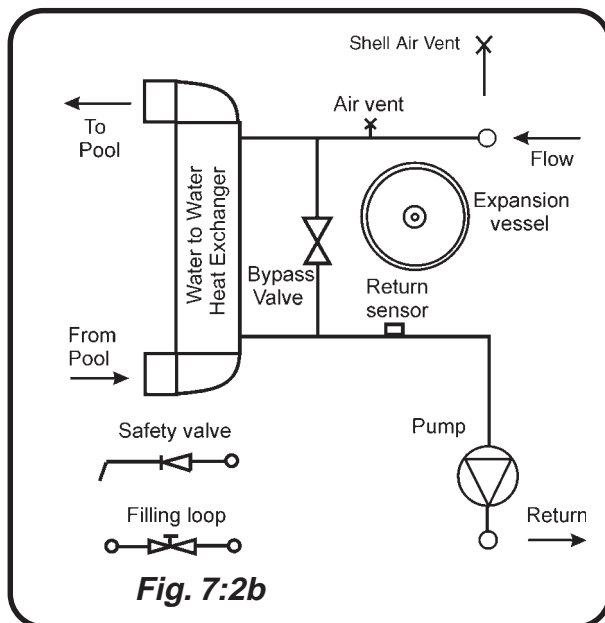

HEATER CONNECTIONS

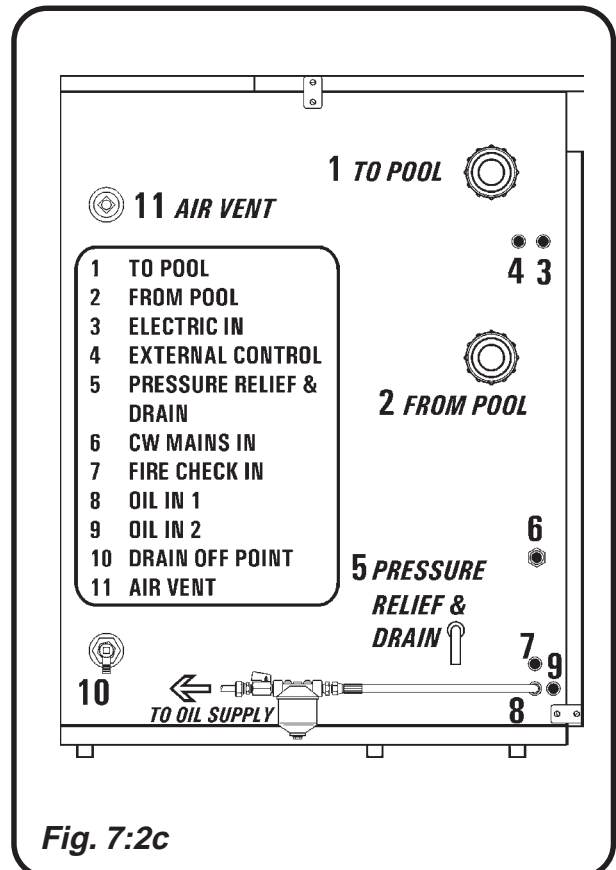

7:3 SETTING UP THE CONTROLS

It is recommended that you familiarise yourself with the functions of the Control. These are detailed in the User Instructions, **Section 1:6 and the Heater Control, Section 4:2.**

There are two options that should be set to suit the user and it also recommended that the Fault Logs are cleared.

1. The display is factory set for Fahrenheit, it can be altered to show Centigrade.
2. If the Heater is also providing Space Heating/DHW, the factory setting of Pool priority may want to be changed to Heating priority. Priority means, whichever is chosen has to be upto temperature before it heats the other.

These settings can be altered, and other data viewed in 'Setup Mode'

Procedure to enter Setup Mode

To enter Setup Mode turn both Temperature Control Knobs to OFF.

The following must be carried out within 5 seconds.

1. Turn on the Mains supply to the Heater.
2. Turn the Pool Temperature Control Knob ON.
3. Turn the Heating Temperature Control Knob ON.
4. Turn the Pool Temperature Control Knob OFF.
5. Turn The Heating Temperature Control Knob OFF.

The Control is now in 'Setup Mode' and displaying the Heater temperature. Additional data is displayed as the Pool Temperature Knob is rotated. **See Fig. 7:3a & Table 7:3.1**

Settings that can be altered are changed by turning the Heating Temperature Control Knob On or Off.

To leave 'Setup Mode' and retain the new settings, turn off the Mains supply for a few seconds at any time.

Note: At power-up the Display is also used to show fault conditions. If an unexpected display is shown please check the Fault Finding Section 10:2.

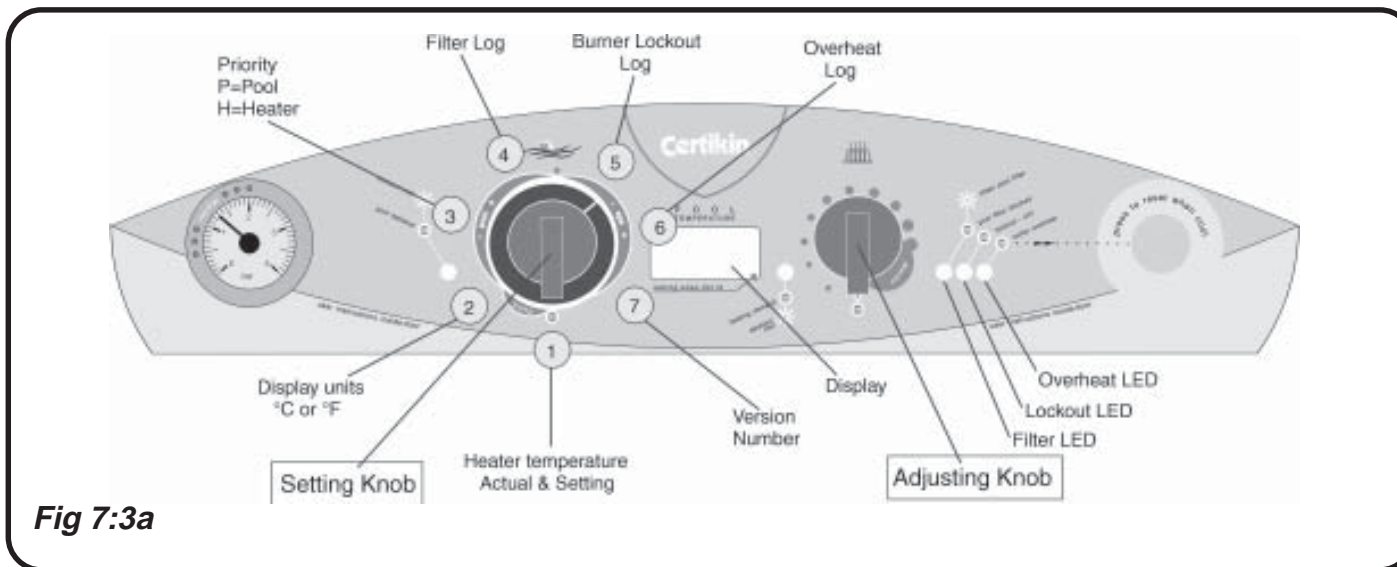

Fig 7:3a

Table 7:3.1 Control Display in Setup Mode.

Setting	Heating Knob On or Off		Fascia Indicator
1 Heater temperature *	Actual temperature	Set temperature	e.g 20 & 70
	Factory setting	Alternative	
2 Display Units	°F = Fahrenheit	°C = Centigrade	°F or °C
3 Priority	P = Pool	H = Heating	P or H
4 Filter Pressure log #	Number of Operations	Resets to zero	Yellow Filter LED On
5 Burner Lockout log #	Number of Operations	Resets to zero	Red Lockout LED On
6 Boiler Overheat log #	Number of Operations	Resets to zero	Red Overheat LED On
7 Version Number	—	—	e.g. 010

* In this position with the Pool Temperature Control off, the Heater can be run for test purposes, if there is a Space Heating demand, by turning On the Heating Temperature Control Knob.

Reset the log by turning the Heating Temperature Control Knob On or Off.

7:4 PRESSURE SWITCH

The pressure switch, ensures that the heater operates only when the filter pump is in operation. It is factory set at 0.12 bar (1.75 PSI) for deck level installations. When the heater is located below the level of the spa or pool, it may be necessary to reset the pressure switch to compensate for the no-flow static head. If it is necessary to reset the pressure switch, we recommend the following procedure:

PRESSURE SWITCH ADJUSTMENT

1. With pump and heater on, turn adjustment knob (clockwise) until a click is heard from the gas valve.
2. Turn adjustment knob (**counter clockwise**) 1/4 turn.
3. Turn pump off and on several times. Heater should shut off immediately. If it does not, repeat steps above until proper adjustments is made.

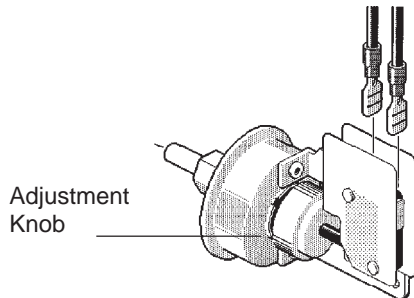

NOTE: If heater is installed outside of the limits shown below, a flow switch must be used in place of the pressure switch when mounted and wired adjacent to the heater.

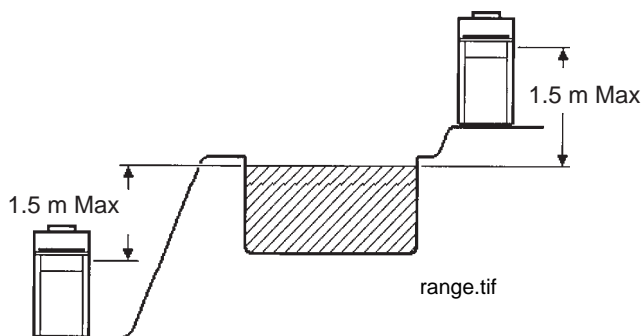

TWO SPEED PUMPS

In some cases, the flow on the low speed is insufficient to operate the heater. This is apparent when the pressure switch cannot be further adjusted or if the heater makes banging noises. In these cases, the pump must be run at high speed when heating the water.

CAUTION: Do not operate the heater without the function of a properly adjusted pressure switch or flow switch.

7:5 RESPONSIBILITY

It is the responsibility of the Installer to ensure that the Heater is properly commissioned. It is essential that the commissioning procedures detailed in this manual are carried out by a qualified engineer using recognised test equipment.

It is recommended that the relevant section of BS 5410: Part 1: latest edition is carefully read.

7:6 REPORTING

It is recommended that you use a report sheet and check list. Make comments on the report where necessary, and give a copy to whoever has engaged your services, and retain and file your own copy. A suggested layout is shown over.

It is the responsibility of the Installer to ensure that the Heater is commissioned by an OFTEC Registered Commissioning Engineer.

7:7 RECOMMENDED COMMISSIONING CHECK LIST - SHEET 1 OF 2

Customer..... Appliance Model.....

Site Address..... Serial No.....

..... Fuel.....

Tick off each item.

OIL TANK

- Is there sufficient oil, and of the correct grade for the appliance?
- Is the tank adequately supported?
- Is a damp-proof membrane inserted between the tank and support? (Non plastic tanks).
- Does the tank slope at least 20 mm per metre of length downwards towards the sludge cock? (Non plastic tanks).
- Is the tank painted or suitably protected externally?
- Is the Tank fitted with the following:
 - Contents gauge
 - Suitable hinged combined fill and vent cover, or capped fill and vent pipes.
 - Outlet valve
 - Filter
 - Sludge cock. (Non plastic tanks).

HEIGHT OF TANK

- Is the bottom of the tank above the oil pump if a single pipe system is installed?

OIL SUPPLY LINE

- Ensure that galvanised iron has not been used.
- If black iron has been used, is it protected against corrosion?
- Ensure that soldered connections on copper pipes have not been used.
- Is the size of pipe adequate for the Heater rating?
- Are all joints leak proof?
- Is a fire valve fitted?
- Is a filter fitted? (correct way round)

- Is the oil line connected to the correct inlet connection of the pump?
- Is the oil supply clean and free of water or other contamination?
- Disconnect oil supply as close to the burner as possible and drain approximately a gallon of oil into a very clean container. Inspect the oil for impurities and repeat the process if necessary.

Do not re-connect the oil line until water and all impurities have been removed from the oil supply.
IF NOT THIS MAY DAMAGE THE PUMP

- Clean oil filters and de-sludge oil tank if necessary.

TWO PIPE OIL SYSTEMS

- Is a spring-loaded non-return oil valve fitted in the suction line? (or a 3K Oil Deaerator).
- Does the return oil line terminate in the tank at the same level as the suction outlet?
- Has an anti-syphon cut been made in the return oil line (inside the tank)?

HEATER

- Is the Heater standing on a level incombustible hearth?
- Are the thermostat sensors inserted in their pockets?
- Are the baffles and bottom insulation (where applicable) correctly located?
- Is the Heater set for the fuel being supplied?
- Is the Heater flueway inspection cover screwed down sufficiently firmly to form a seal?
- Is the central Screw in the Access Panel tightened down finger tight to stop the baffles rattling?

- Has the Heater been filled with mains water and the Filling Loop been removed?
- Have the Pool water connections been made to the correct fittings?

CASING PANELS

- Have grommets been fitted to relevant oil supply entry points?
- Have the grommet cable entry connections been used?

BURNER

- Is the oil pump by-pass screw fitted, if applicable?
- Remove the burner. Is the correct nozzle fitted?
- If the burner has an adjustable head, do the settings agree with those given in the Heater instructions?
- Is the Air Shutter adjustment correct?

NOTE:- Burner operating instructions can conflict because they are intended for general guidance. Since the burner has been specifically matched to the particular Heater, the information in the Heater manual takes precedence.

FLUE

- Is the flue adequately sized for the appliance rating?
- Is the flue free of any obstruction?
- Has the chimney been adequately lined and insulated?

NOTE:- Lining the flue and back filling will help prevent condensate problems.

BALANCED FLUE APPLIANCES

- Can leakage from flue tubes or air ducts occur?

VENTILATION

CONVENTIONAL FLUED HEATERS

- Is the ventilation opening from the outside to the Heater room adequate?
- Is there sufficient clearance for air to enter the Air Entry Plates on side or rear of appliance?

- Will any ventilation fans prevent adequate supply of combustion air?

ELECTRICAL POWER SUPPLY

- Is the electrical supply to the appliance appropriate?
- Are the electrical input connections to the control panel correct?
- Are the electrical connections from the Heater control panel to the burner correct?
- Is the supply fuse correct?
- Does the wiring comply with the latest IEE Regulations?
- Does the power supply cable enter the casing through an air tight cable grip?

GENERAL

- Has the Heater been installed in accordance with manufacturers instructions?

7:8 RECOMMENDED COMMISSIONING TESTS

- Have the manufacturers on-site assembly instructions been followed?

COMMISSIONING TESTS

BEFORE ATTEMPTING TO START THE HEATER PLEASE THOROUGHLY CHECK ALL ITEMS ON THE COMMISSIONING CHECK LIST. THIS WILL HELP TO AVOID UNNECESSARY CALL BACKS

- Fill Heater following the steps detailed in 7:2.
- With the plug for the burner NOT fitted, turn on electricity supply and by using the switch on the Pool Thermostat Control, run the internal pump in short bursts to bleed the air from the Manual Air Vents.
- When running quietly, turn off and reconnect the burner.
- Fit combined air bleed manifold and 0-300 psi (0-20 bar) pressure gauge to the appropriate oil pump connection, and replace burner.
- Set the Heater Pool Thermostat Control to above the actual temperature.

- When the burner motor starts, on one pipe systems it may be necessary to temporarily open the air bleed screw on the test manifold.
- If the burner locks out during the ignition attempt, wait 45 seconds before pressing the reset button on the control box. Several attempts on first firing may be necessary.
- Once the burner is firing check and if necessary adjust the oil pressure.

CARRY OUT COMBUSTION CHECKS BY INSERTING PROBES INTO SAMPLING POINTS PROVIDED:

- Balanced flue, - hole provided in outlet end of terminal.
- Conventional flue - drill a small hole in the flue pipe, between the flue spigot and casing top panel (large enough to accept the sampling probe).
- Check the Smoke No., if clean wait 10 minutes and measure CO₂.
- Adjust the air shutter if necessary, open to reduce CO₂, close to increase CO₂.
- If the air shutter is adjusted, re-check the Smoke No.
- Check the flue gas temperature.
- The figures should agree with the Heater Commissioning Data.
- Check lockout function, either cover the photocell, or remove solenoid coil, to simulate flame failure. Re-instate components and press lockout button.
- Complete commissioning report.
- Instruct the user on the operation of the Heater and leave the operating instructions with the customer.

8: MAINTENANCE
8:1 GENERAL INFORMATION

A Heater fired with Class C Oil should only require attention once each year, whereas with Class D Oil, attention twice each year may be required.

8:1.1 Inspection

With the Heater operating, inspect for signs of unsatisfactory operation, i.e. leakage of combustion products, leakage of oil, or unusual noises from the pump or motor.

Check the commissioning list if it is your first attendance to the appliance. Is there a reason why the Heater might fail after you leave?

It is useful to measure the combustion data, i.e. CO₂, Smoke No. and flue gas temperature, and a check on the oil pressure, prior to carrying out maintenance work.

8:1.2 Winterisation

Provided there is a Mains and Oil Supply to the Heater, the controls will automatically protect against freezing in the following way.

At 3°C (37°F) the Heater will turn on its Internal Pump, and if connected the Pool Pump.

If this fails to raise the temperature to 5°C (41°F) within 5 minutes the Pool Pump is turned off and the burner fired until the Heater reaches 10°C (50°F). If this automatic protection is not required the Mains Supply to the Heater should be switched off.

Additionally, the Heater can be protected by draining down or protecting with Anti-freeze. The Manufacturer recommends Betz Dearborn X500 Anti-freeze in the following doses.

Model	Water content	X500 (Anti Freeze & Inhibitor)	Inhibitor Alone
110	20 litres	½ a X500 Cubitainer	¼ of a 1 litre X100
180	40 litres	One X500 Cubitainer	½ of a 1 litre X100
220	40 litres	One X500 Cubitainer	½ of a 1 litre X100
280	70 litres	1½ X500 Cubitainer	1 of a 1 litre X100

The above Anti-freeze concentrations will provide protection down to -15°C.

8:1.3 Maintenance Procedure

Switch off electrical supply at the MAINS ISOLATING SWITCH.

OIL TANK

- De-sludge oil tank (if necessary), and draw off any accumulated water.
- Check the correct grade of oil is being used.

FILTERS

- Inspect and clean all oil filters. Change paper elements for new.

BURNER

- Turn off the oil cock and disconnect the flexible oil hose from the oil cock.
- Remove burner and clean thoroughly, the burner draught tube, the electrodes and generally the head assembly. CHANGE the nozzle for one with the specified make, oil rate, spray pattern and angle.
- Inspect the ignition electrodes for crazing in the porcelain. Replace if there are signs of deterioration.
- A dirty fan impeller can impair the performance of burner, inspect and clean if necessary.
- Inspect photocell, if badly discoloured, change it.
- Inspect the flexible oil hose for leaks or discoloration. Use only replacement flexible oil hoses that are detailed in the spare parts section of this manual.

HEATER

All models are serviced from the front.

- Remove flueway inspection cover/s, and baffles, and clean all heat transfer surfaces and baffles.
- Replace any damaged or unserviceable parts with manufacturers proprietary parts.
- Inspect flue and air ducts for deterioration of seals, and repair if necessary.
- Refit parts and inspect seals etc. which should be replaced if required.

COMBUSTION TESTS

- Fit combined air bleed manifold and 0-300 psi (0-20 bar) pressure gauge to the appropriate oil pump connection, and replace burner.
- Switch on the electric supply to the Heater.
- When the burner motor starts, on one pipe systems, it may be necessary to temporarily open the air bleed screw on the test manifold.
- Once the burner is firing check and if necessary

adjust the oil pressure.

- Carry out combustion checks by inserting probes into sampling points provided or at the flue outlet. See illustrations of balanced flue kits. On CF Heaters drill a small hole in the flue pipe, but after measurement, plug the hole.
- Check the Smoke No., if clean wait 10 minutes and measure CO₂.
- Adjust the air shutter if necessary, open to reduce CO₂, close to increase CO₂.
- If the air shutter is adjusted, re-check the Smoke No.
- Check the flue gas temperature.
- The figures should agree with data in Heater Commissioning Data, **Section 3:6**.

FINAL CHECKS

- Check lockout function, either remove photocell and cover it, or remove solenoid coil, to simulate flame failure. Re-instate components and press lockout reset button.
- Check that the control thermostat is operating when the set temperature is reached.
- Complete a maintenance report and give the customer a copy, retaining a copy for your records.

8:2 AIR SHUTTER ADJUSTMENT

- The Burner has a fixed Air Shutter with manual adjustment.
- The Air Setting is set by the Manufacturer before despatch but may require fine adjustment on site.
- The Commissioning Data - Section 3:6, gives recommended Air Shutter adjustment for given output.
- To adjust the Air Shutter use a spanner or allen key as shown in Fig 8:2a. To increase the setting turn the air shutter anti-clockwise and to decrease turn clockwise.

NOTE: For accurate reading of the setting it is necessary to remove the Burner to see the Scale.

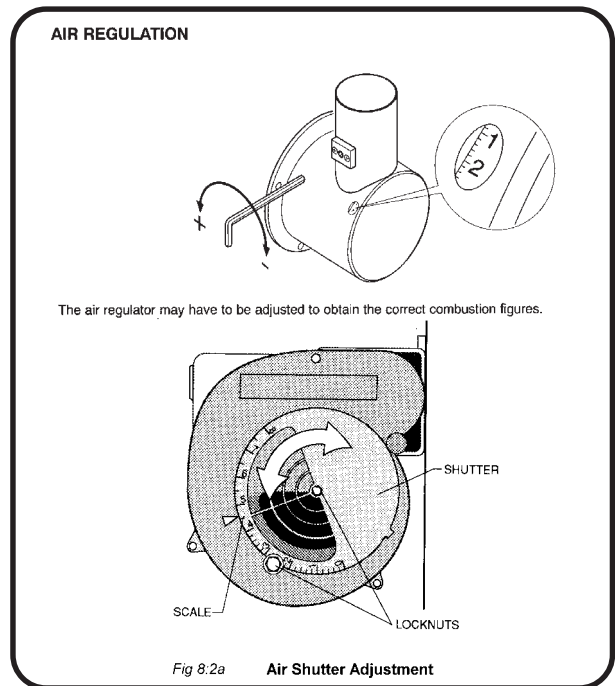

8:3 BAFFLE ARRANGEMENT

Model 110 only

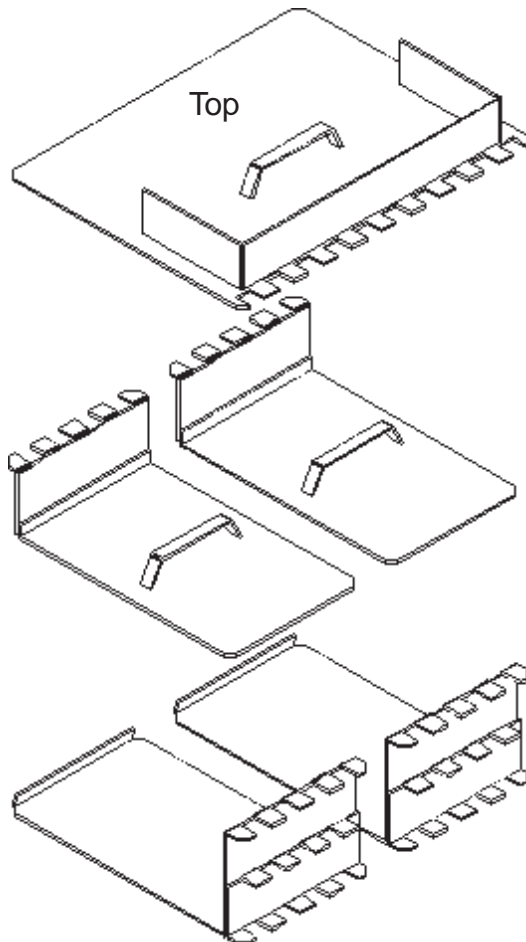

Fig 8:3a

Model 180 only

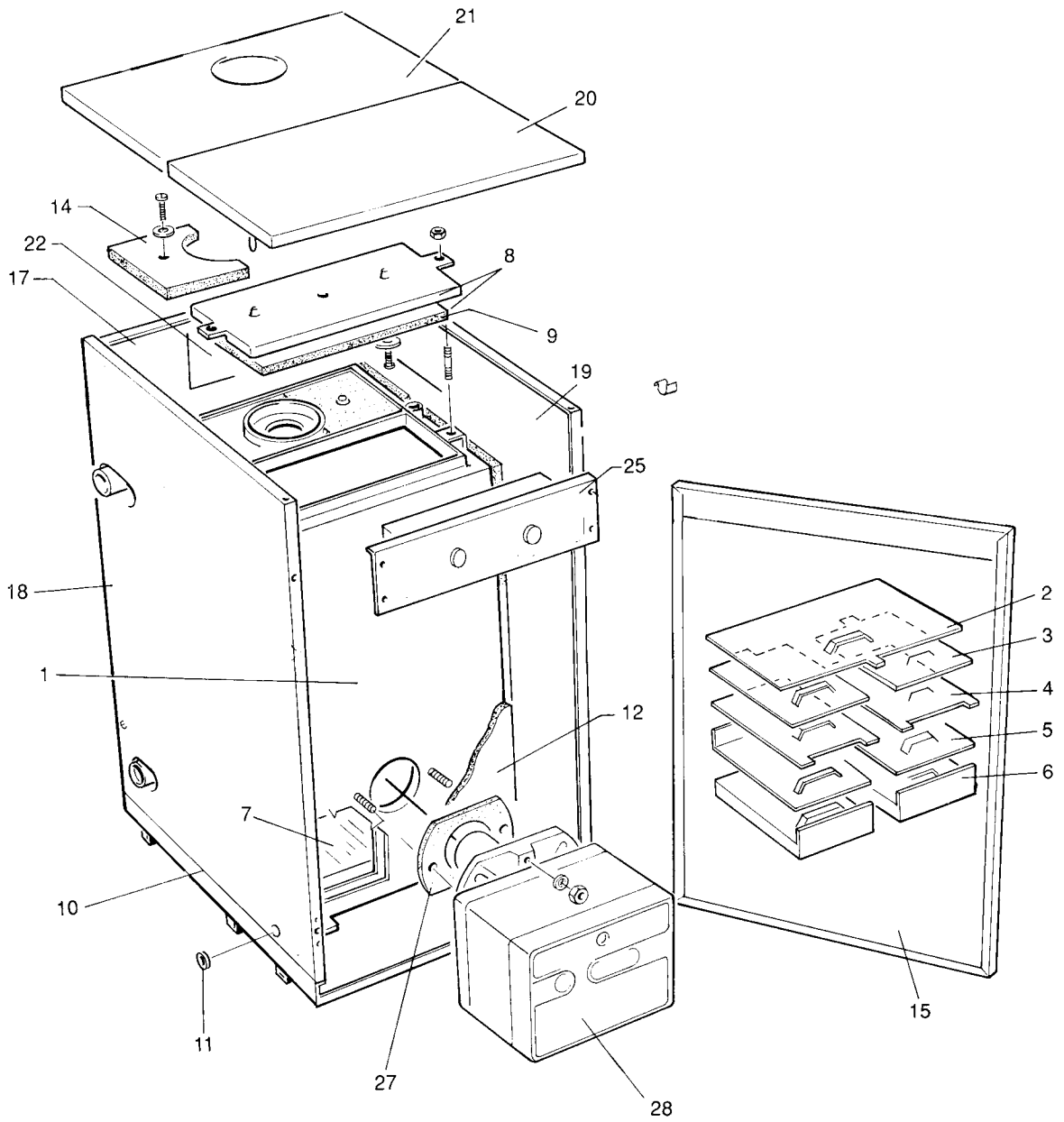

Fig 8.3b

Baffle Arrangement

Model 220 only

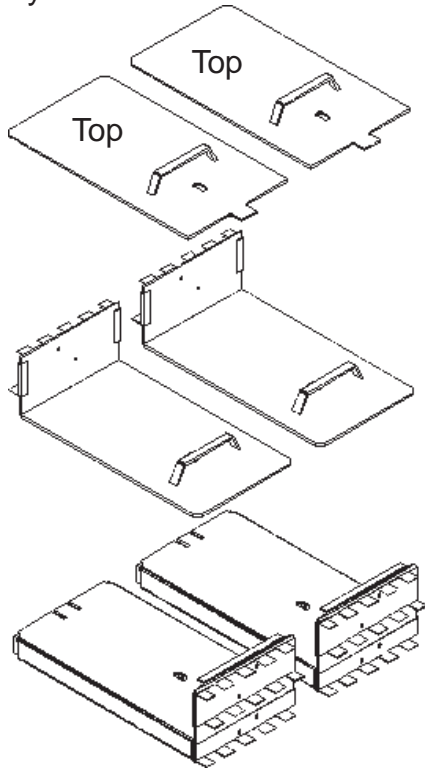

Fig 8:3c

Model 280 only

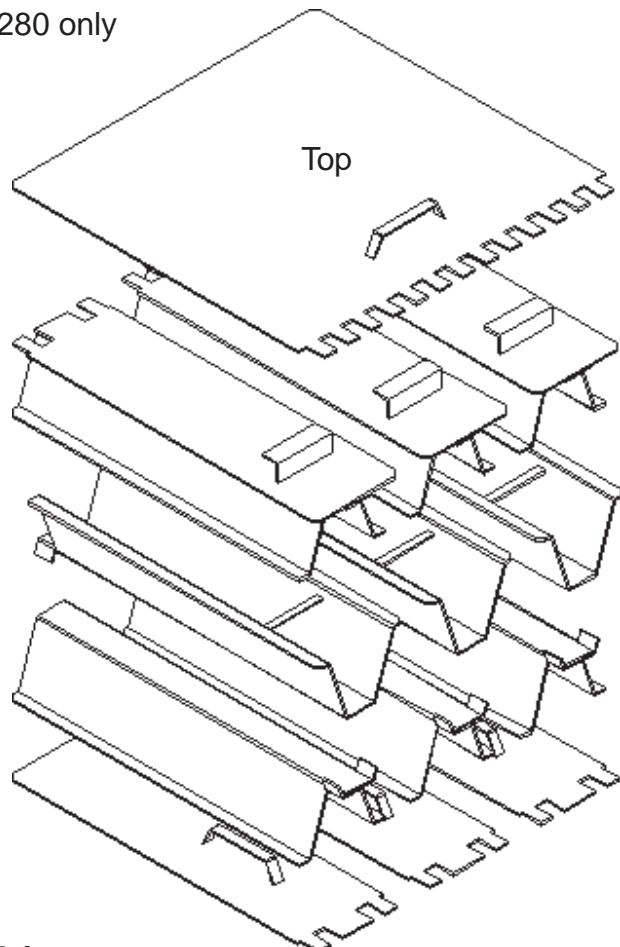

Fig 8:3d

9: SPARE PARTS

9:1 PARTS

See Fig 8:3b for Item Numbers.

Item	Description	110	180	220	280
1	Heat Exchanger HE 51351C	HE 26451C	HE 14551C	HE 47651C	
2	1st Baffle	HE 51031C	HE 23041C	2 off HE14034C	2 off HE47061
3	2nd Baffle 2 off unless stated	HE 51032C	HE 23042C	HE14035C	3 off HE47062C
4	3rd Baffle 2 off unless stated	HE 51033C	HE 23043C	HE14036C	3 off HE47063C
5	4th Baffle 2 off unless stated	—	HE 23044C	—	3 off HE47063C
6	5th Baffle 2 off unless stated	—	HE 23046C	—	3 off HE47067
7	Combustion Chamber Base Insulation	2 x IN51303	2 x IN14403	2 x IN14403	3 x IN47603
8	Inspection Cover complete	HE 37318C	HE 14418C	HE14418C	HE47618C
9	Inspection Cover Insulation	IN37301	IN14402	IN14402	IN47602
10	Base Tray	PN37331C	PN31301C	PN31301C	PN47501C
11	Grommet	RP00610	RP00610	RP00610	RP00610
12	Heat Exchanger Insulation Set	IN37350C	IN26350C	IN26350C	IN47500C
14	Flueway Insulation Ceraboard (pair)	—	IN14401	IN14401	—
15	Door Panel	M4436	M4542	M4542	M4494
17	Rear Casing Panel	M4437	M4543	M4543	M4492
18	Left side Casing Panel	M4435	M4538	M4538	M4488
19	Right side Casing Panel	M4438	M4544	M4544	M4491
20	Top Casing Panel Front (Assy.)	M4586	M4548	M4548	M4504
21	Top Casing Panel Rear	M4584	M4559	M4545	M4500
	Rear/Side Casing Blanking Panel	M4589	M4557	M4557	M4505
	Top Panel Blanking Panel	M4561	M4561	M4560	M4506
27	Burner Gasket	RP03001	RP03002	RP03002	RP03002
28	Burner Complete	3744363	3745960	3746457	3748960
	Automatic Air Vent	6166	6166	6166	6166
	Safety Valve	SPCOH012	SPCOH012	SPCOH012	SPCOH012
	Bulkhead Valve	M0619	M0619	M0619	M0619
	Expansion Vessel	SPCOH103	SPCOH103	SPCOH103	SPCOH103
	Secondary Heat Exchanger	M4477	M4374	M4374	M4374
	Pressure Switch (Plastic thread)	651284	—	—	651284
	Pressure Switch (Copper Pig-tail)	-	650634	650634	—
	Seal Ring Flue, Green, 60mm	SPCOHBF04	SPCOHBF04	—	—
	Seal Ring Air, Brown, 100mm	SPCOHBF05	SPCOHBF05	—	—
	Seal Ring, Flue, Black, 2x lip, 120mm	—	—	SPCOHBF07	SPCOHBF07
	Seal Ring Air, Black, 1x lip, 170mm	—	—	SPCOHBF08	SPCOHBF08
	Gasket, Low Level Terminal	SPCOHBF01	SPCOHBF02	SPCOHBF02	—
	Gasket, 170 x 170 mm	SPCOHBF03	SPCOHBF03	—	—
	Gasket 195 x 195 mm	—	—	SPCOHBF06	SPCOHBF06
	Gasket, 185 x 185 mm	—	—	SPCOHBF09	SPCOHBF09
	Nozzle Kerosine	BS11106	BS11110	BS11112	BS11114
	Nozzle Gas Oil	SPCOH2/009	SPCOH2	SPCOH26	SPCOH2/012
	Pump UPS 25-60	M0623	M0623	M0623	
	Pump UPS 25-55				M4024

ELECTRICAL ASSEMBLY - All Models

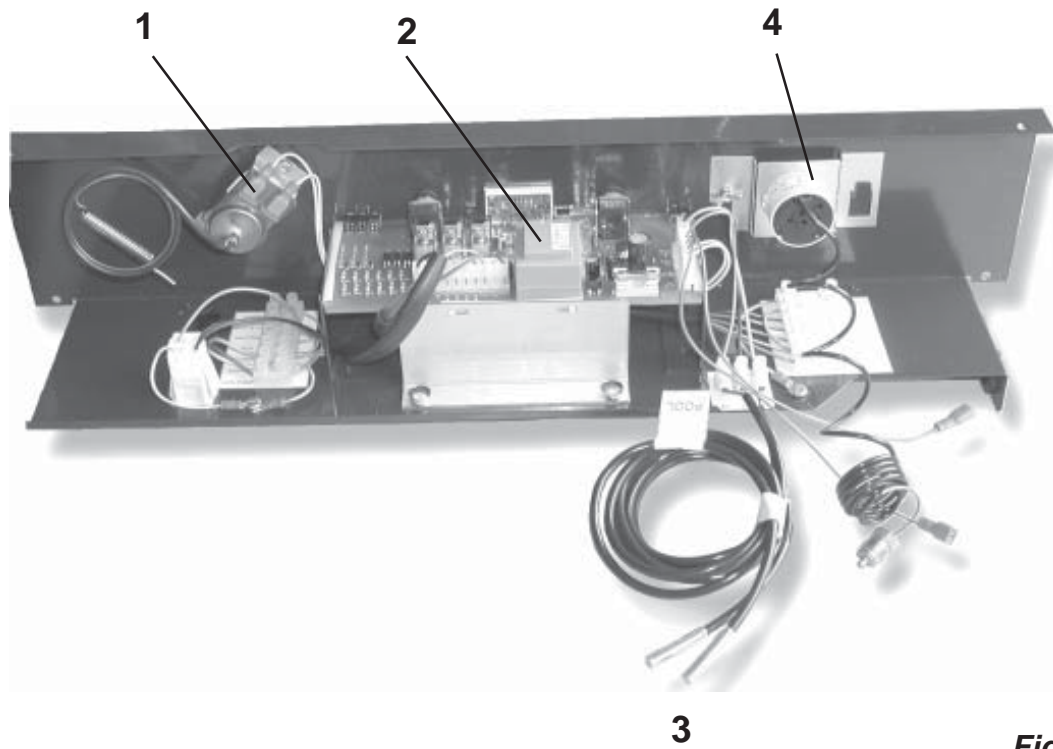

Fig 8:3e

Item	Description	All Models
1	High Limit Stat	SPCOH015
2	Control Board	SPCOH2/001
3	Boiler & Pool Temperature Sensor	SPCOH2/002
4	Pressure Gauge	SPCOH2/003
5	Control Knob (2 Places, not shown)	SPMB3411
6	Stop Ring (not shown)	SPMB515
7	Bypass valve (not shown)	SPCOH034
8	Reset grommet (not shown)	SPCOH2/007
9	Bypass Sensor (not shown)	SPCOH2/004

9:2 ACCESSORIES

	110	180	220	280
Standard Horizontal Balanced Flue Kit	SPCOHBF1	SPCOHBF2		SPCOHBF3
Extended Horizontal Balanced Flue Kit	SPCOHBF1L	SPCOHBF2L		uses extensions
Terminal Guard	SPCOHTG1			SPCOHTG2
Outdoor Vertical Kit	SPCOHBFOV10	SPCOHBFOV11		PCOHBFOV3
Vertical Balanced Flue Adapter & Terminal	SPCOHBFIV1		SPCOHBFIV2	SPCOHBFIV3
Short Vertical Balanced Flue Extension	SPCOHBFV15E		SPCOHBFV25E	
Long Vertical Balanced Flue Extension	SPCOHBFV11E		SPCOHBFV21E	

Model 110 - 443T58

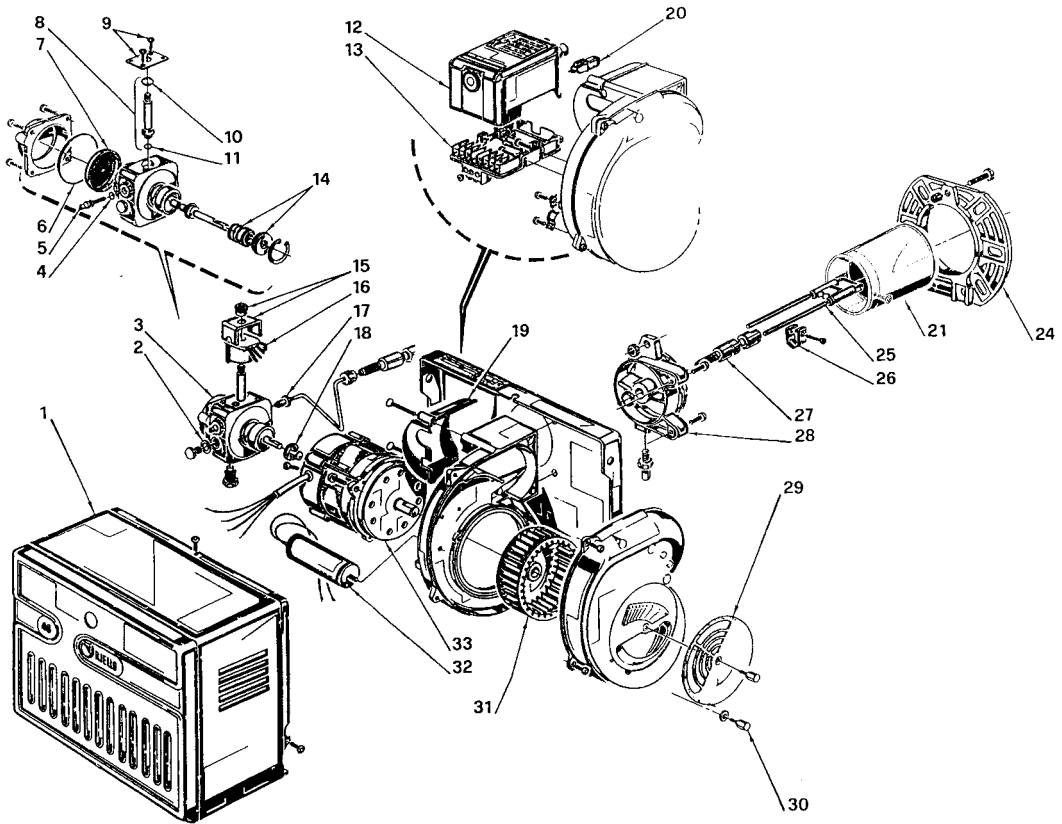

CODE	DESCRIPTION	CODE	DESCRIPTION
1	3008473 Burner Cover	18	3000443 Joint
2	3007077 Seal	19	3006556 Cover
3	3007811 Pump	20	3002280 Photoresistance
4	3007028 O Ring	21	3006001 Blast tube assembly
5	3007202 Regulator	22	
6	3007162 O Ring	23	
7	3005719 Filter	24	3007798 Flange
8	3006925 Needle Valve	25	3007708 Electrode assembly
9	3007203 Plate	26	3006552 Electrode bracket
10	3007029 O Ring	27	3005724 Nozzle holder
11	3007156 O Ring	28	3007796 Collar
12	3001156 Control Box 530SE	29	3007204 Air damper
13	3002278 Control Box base	30	3008448 Screw
14	3000439 Pump seal	31	3005708 Fan
15	3006553 Shell	32	3005798 Capacitor 4µF
16	3002279 Coil	33	3007355 Motor
17	3008472 Tube		

The following items are supplied but not shown

- RP03001** Flange Gasket
- 3005720** Economy Hose
- 3003602** Hose adaptor 3/8 - 1/4"

Fig 8:4a

Model 180 - 459T55

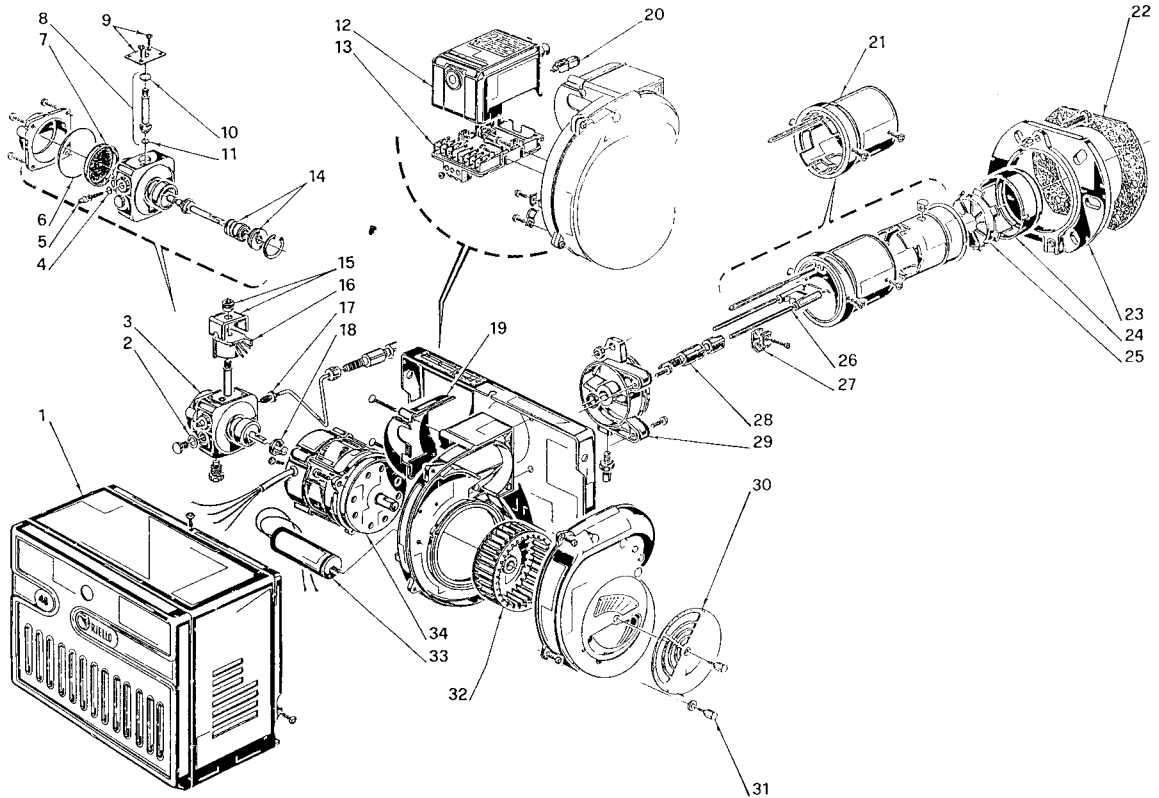

Item	Part No.	Description
1	3008450	Body
2	3007077	Seal
3	3007811	Pump
4	3007028	O-Ring
5	3007202	Regulator
6	3007162	O-Ring
7	3005719	Filter
8	3006925	Valve Assembly
9	3007203	Plate
10	3007029	O-Ring
11	3007156	O-Ring
12	3001156	Control Box 530SE*
13	3002278	Control Box Base
14	3000439	Pump Seal
15	3006553	Shell and Knob
16	3002279	Coil
17	3005789	Tube

Item	Part No.	Description
18	3000443	Coupling
19	3006557	Cover
20	3002280	Photoresistance
21	3007714	Blast Tube Assembly
22	3005795	Gasket
23	3005796	Flange
24	3005714	End Ring
25	3005713	Diffuser Disc
26	3007713	Electrode Assembly
27	3006552	Electrode Bracket
28	3005709	Nozzle Holder
29	3005791	Collar
30	3007907	Air Damper
31	3008448	Screw
32	3005788	Fan
33	3005798	Capacitor 4 μ F
34	3007355	Motor

Fig 8:4b

Model 220 - 464T55

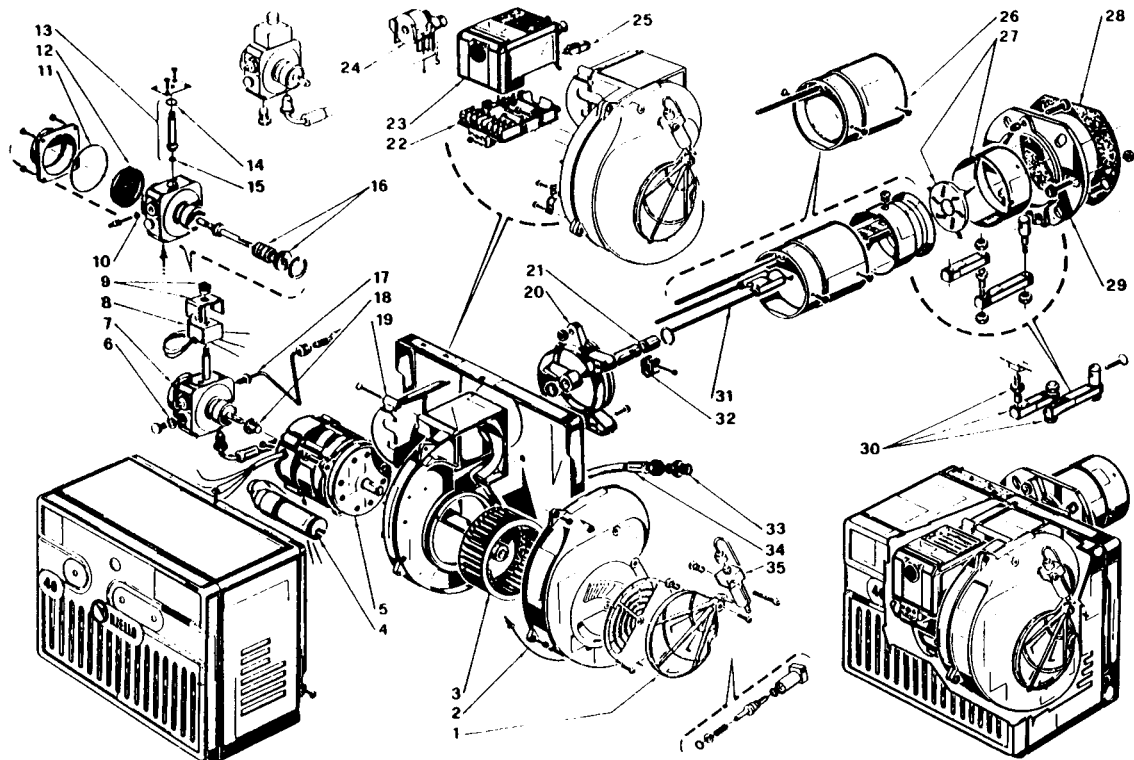

CODE	DESCRIPTION	CODE	DESCRIPTION		
1	3000879	Air damper	20	3005791	Collar
2	3006913	Oil pipe	21	3005764	Nozzle holder
3	3005788	Fan	22	3002278	Control box base
4	3005798	Condenser	23	3001156	Control box
5	3007355	Motor	24	3002297	Transformer
6	3007077	Washer	25	3002280	Photo cell
7	3007811	Pump	26	3006151	Blast tube
8	3002279	Coil	27	3005793	Disc
9	3006553	Cage and nut	27	3005794	Ring
10	3007028	O ring	28	3005975	Gasket
11	3007162	O ring	29	3005796	Flange
12	3005719	Filter	30	3000640	Hinge
13	3006925	Valve assembly	31	3005790	Electrode
14	3007029	O ring	32	3006552	Electrode clamp
15	3007156	O ring	35	3006911	Hydraulic jack
16	3000439	Shaft seal			
17	3005789	Oil pipe			
18	3000443	Coupling			
19	3006557	Half casting			

Fig 8:4c

Model 280 - 489T50

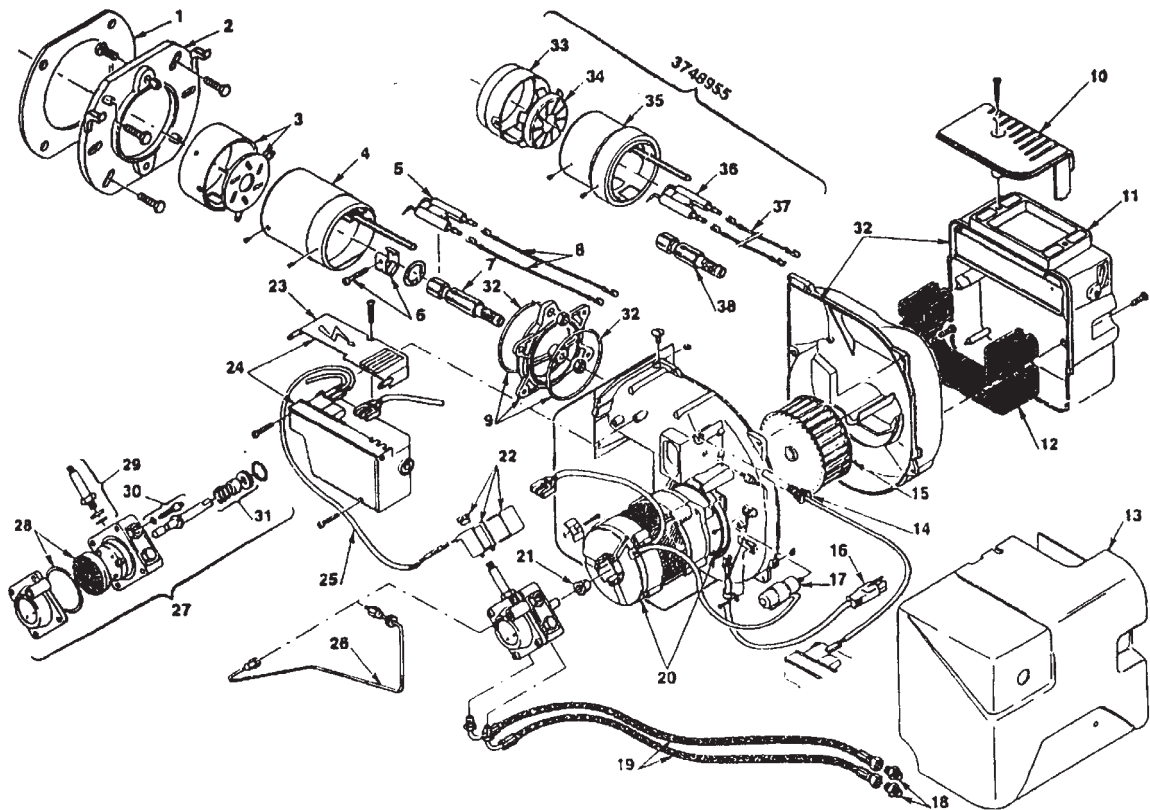

Fig 8:4d

Item	Code	Description	Item	Code	Description
1	3005795	Gasket	20	3008964	Motor
2	3008637	Flange	21	3000443	Joint
7	3002570	Nozzle Holder	22	3008648	Coil
8	3008956	High Voltage Lead	23	3008649	Protective Cover
9	3008957	Collar	24	3008652	Control Box 535se/ld
10	3008959	Air Test Point	25	3008851	Solenoid Lead
11	3008839	Air Damper Assembly	26	3008961	Tube
12	3008958	Deadening	27	3008654	Pump
13	3008982	Cover	28	3008653	Filter, O Ring
14	3008646	P.E Cell	29	3007582	Needle Valve
15	3006799	Fan	30	3008651	Regulator
16	3008863	Lead	31	3000439	Pump Seal
17	3008960	Capacitor 5 μ F	32	3008963	Kit Seals
			34	3002571	Diffuser Disc & Electrode Assy
			35	3002572	Blast Tube Assembly

10: FAULT FINDING

10:1 GENERAL

If the Heater fails to start, make the following checks.

1. Is there sufficient fuel in the storage tank?
2. Are all fuel supply valves open (turned fully anti-clockwise) and ball valves open?
3. Is the mains electricity supply switched On?
4. Is there a Demand for Pool or Space Heating?
5. For Space Heating is the Heater Thermostat set to the desired temperature?
6. Check the fuses which should have been fitted to the mains electricity supply to the Timeswitch/ Heater. If the fuse has blown. Replace it. If it blows again, call a Service Engineer.
7. Is the Filter LED lit? If it is, check Pool Pump is running and the Filter is not blocked.
8. Is the Lockout LED lit? If it is, press the Reset Button on Burner.
9. Is the Overheat LED lit? If it is press the Reset on the Control Panel.

If the fault is not permanently corrected by one of these actions it is likely that a component is faulty and will need replacing. This should only be carried out by someone competent to do so.

IMPORTANT - Electrical Safety

IT IS ESSENTIAL THAT BEFORE ANY PANELS OR COMPONENTS ARE REMOVED FROM THE HEATER, THAT THE MAINS ISOLATOR IS SWITCHED OFF.

10:2 CONTROL FAULT DIAGNOSIS

Before commencing a diagnosis it is recommended that you familiarise yourself with the functions of the Controls. These are detailed in the *Users Instructions Section 1:6* and in *Heater Control, Section 4:2* The Control will diagnose and display most of its own faults.

Self Check

The Control does a full self check during power up. It also briefly lights all the LEDs and the Temperature Display so they can be checked for operation.

Demand Inputs

The front panel LEDs for Pool Demand and Heating Demand are triggered from the Mains Inputs and the chosen Priority. If they are not lit check the supplied voltage, connections and Priority setting.

Relay Outputs

LEDs on the Control Board, beside the relays, are directly connected to the relay outputs and show if there is an output voltage to the Burner, Internal Pump or Pool Pump. If they are not lit check the output voltages, if correct replace the board. If lit,

check voltage at the component, replace if correct.

Displayed Faults

The Control board detects and displays certain fault conditions. The display alternates between two codes.

Display	Reason	Action
Err / No	<i>Control board fault.</i>	Power Off then On again. If not corrected replace board.
b / oc	<i>Boiler sensor Open Circuit.</i>	Check connections, if correct, replace sensor.
P / oc	<i>Pool sensor Open Circuit.</i>	Check connections, if correct, replace sensor.
b / cc	<i>Boiler sensor Short Circuit.</i>	Check connections, if correct, replace sensor.
P / cc	<i>Pool sensor Short Circuit.</i>	Check connections, if correct, replace sensor.

Logs

The Control keeps a log of the number of times the Pressure Switch, the Burner Lockout and the Overheat Switch operate. These can be examined and reset to zero in Setup Mode. The Temperature Display units and Priority can also be checked and altered in this mode.

Setup Mode

To enter Setup Mode turn both temperature control knobs to OFF.

To enter Setup Mode turn both Temperature Control Knobs to OFF.

The following must be carried out within 5 seconds.

1. Turn on the Mains supply to the Heater.
2. Turn the Pool Temperature Control Knob ON.
3. Turn the Heating Temperature Control Knob ON.
4. Turn the Pool Temperature Control Knob OFF.
5. Turn The Heating Temperature Control Knob OFF.

The Control is now in 'Setup Mode' and displaying the Heater temperature. The Display can now show additional data as the Pool Temperature Knob is rotated. *See Fig 10:2a & Table 10:2.1.*

Settings that can be altered can be changed by turning the Heating Temperature Control Knob On

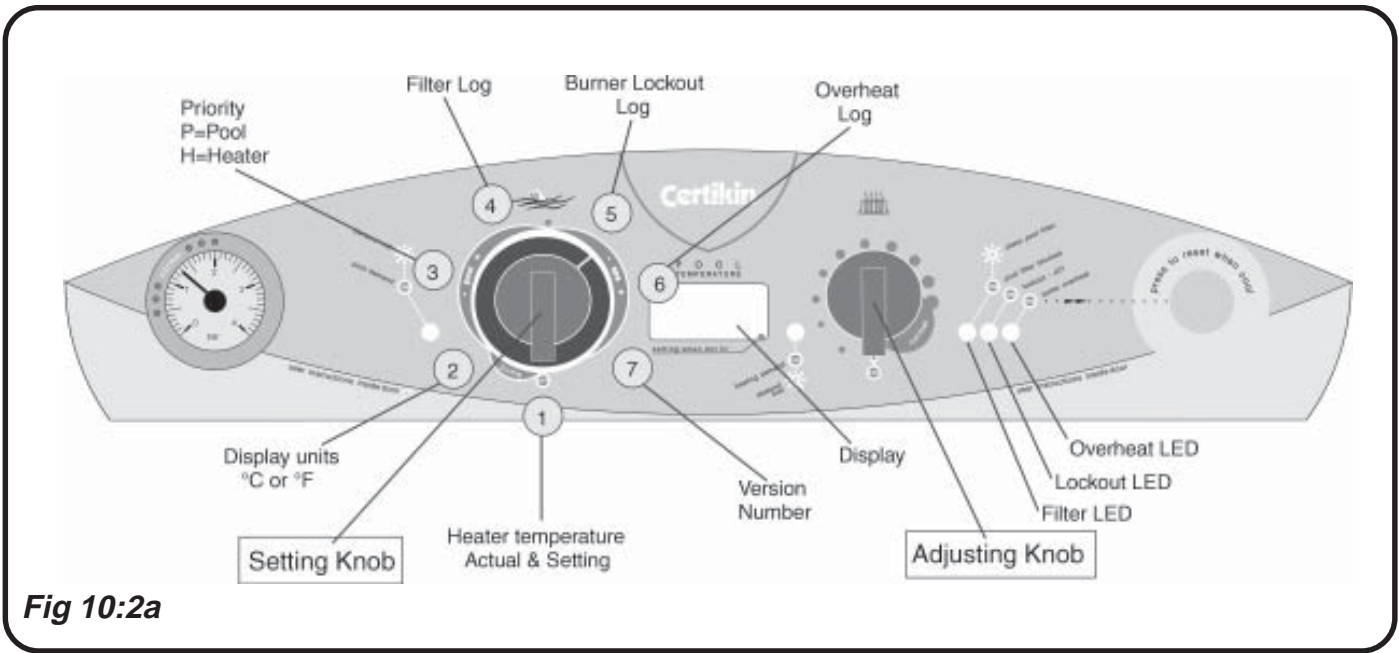

Fig 10:2a

Table 10:2.1 Control Display in Setup Mode.

Setting		Heating Knob On or Off		Fascia Indicator
1	Heater temperature *	Actual temperature	Set Temperature	e.g. 20 & 70
		Factory setting	Alternative	
2	Display units	°F = Fahrenheit	°C = Centigrade	°F or °C
3	Priority	P = Pool	H = Heating	P or H
4	Filter pressure log #	Number of Operations	Resets to zero	Yellow Filter LED on
5	Burner Lockout log #	Number of Operations	Resets to zero	Red Lockout LED on
6	Boiler Overheat log #	Number of Operations	Resets to zero	Red Overheat LED on
7	Version number	-	-	e.g. 010

* In this position with the Pool Temperature Control Knob Off, the Heater can be run for test purposes, if there is a Space Heating demand, by turning On the Heating Temperature Control Knob.

Reset the log by turning the Heating Temperature Control Knob On or Off.

10:3 FAULT FINDING CHART

Trouble or Complaint	Possible Cause	Action
1. Suspect oil supply	<p>No oil in tank</p> <p>Supply valves closed</p> <p>Blockage in oil supply (Gravity head feed)</p> <p>Wrong grade of oil</p> <p>Water contamination</p> <p>Tank vent blocked</p> <p>Filter blocked</p> <p>Air locks in supply pipe</p> <p>Air lock in pump line.</p>	<p>Check and arrange for tank to be filled if necessary.</p> <p>Open all supply valves</p> <p>Shut off the burner isolating valve. Disconnect the oil supply at the pump entry. Place receptacle under the pipe. Slowly open the valve, note if the flow is unrestricted, restricted or blocked.</p> <p>Check for correct grade of fuel (see technical data).</p> <p>Open tank, drain valve and check.</p> <p>Check.</p> <p>Check for water or blockage.</p> <p>Check for high points in main oil supply.</p> <p>Bleed pump, check flexible oil</p>
2. Burner will not start	<p>Interruption or absence of electrical supply at burner. (Check this at control box mains terminal with test lamp).</p> <p>Control box is locked out, refer to symptom 4</p> <p>Photo-resistor receiving false light</p> <p>Faulty control box</p>	<p>Check mains switch is on. Check fuses. Check that time switch contacts are closed. Check that any auxiliary stat are closed. Check there is a demand light on the Heater. Check there the Relay indicators are lit on the Control Board.</p> <p>Press reset button on the burner box.</p> <p>Check that the photo-resistor is fully home in its housing. Burner will not start with illuminated cell.</p> <p>Replace.</p>
3. Burner Lights up but locks out after 15 seconds.	<p>No oil supply.</p> <p>Photo-electric cell not receiving light from flame.</p> <p>Photo-electric cell connections loose.</p> <p>Control box photo-electric cell circuit faulty.</p> <p>Flame instability.</p>	<p>Check oil in tank.</p> <p>Check that Photo-electric cell is clean and fullyhome in its housing.</p> <p>Check and tighten as necessary.</p> <p>Replace control box.</p> <p>Check combustion setting out and reset if necessary.</p>

Trouble or Complaint	Possible Cause	Action
4. Burner starts but will not light up.	<p>This can be due either to absence of oil or ignition</p> <p>Oil pump air locked, (repeated air locking may be due to poor pipe joints or defective gland packing).</p> <p>Motor not driving pump shaft.</p> <p>Blocked atomiser nozzle.</p> <p>Oil pressure abnormally low.</p> <p>Solenoid valve faulty.</p> <p>Pump rotation incorrect.</p> <p><i>Ignition failure.</i> Electrodes dirty</p> <p>Electrode miss-set</p>	<p>Pump should be self-venting with two pipe system only. If a one pipe gravity feed is employed it must be purged through the vent port.</p> <p>Check that flexible drive is functioning correctly and not slipping.</p> <p>Remove and replace nozzle.</p> <p>Check oil pressure gauge and set to the correct pressure (see Technical data).</p> <p>Break union at outlet to check presence of oil. Check that seat is clear. Check coil for continuity. Inspect coil feed wiring to control box.</p> <p>Check.</p> <p>Inspect and clean if necessary.</p> <p>Inspect and reset gap to 3-4mm between tips, 2mm in front of nozzle face.</p>
5. Burner lights up, runs continuously and emits visible smoke or shows excess smoke on combustion check.	<p>Cracked electrode insulator.</p> <p>Air shutter closed.</p> <p>Wrong nozzle.</p> <p>Worn atomiser nozzle.</p> <p>Oversize nozzle fitted in error.</p> <p>Nozzle incorrectly stamped.</p> <p>Burner air supply inadequate.</p> <p>Burner oil pressure excessive.</p>	<p>Check and replace if cracked or crazed.</p> <p>Reset to correct position.</p> <p>Check make, type and spray angle.</p> <p>Replace if necessary.</p> <p>Check size and replace with correct size if necessary.</p> <p>Replace with correct nozzle.</p> <p>Inspect air intake and fan for fouling of impeller with dirt.</p> <p>Check pressure and reset to correct pressure (see Technical data).</p>
6. Burner lights up, runs normally but flame cuts off slowly on shut down (possibly with smoke or pulsation).	<p>Air in nozzle.</p> <p>Magnetic valve not operating correctly.</p> <p>Shut off piston in pump sticking.</p>	<p>Should self-correct; if air repeatedly present; check for leaks on oil line and flexible.</p> <p>Inspect and replace if necessary.</p> <p>Replace pump.</p>

Trouble or Complaint	Possible Cause	Action
<p>7. Burner pulsates (a) continuously.</p> <p>(b) at initial firing.</p>	<p>Air shutter setting incorrect or fan inlet blocked.</p> <p>Grossly oversized nozzle.</p> <p>Air supply inadequate.</p> <p>Worn nozzle with excess throughout or uneven spray pattern.</p> <p>Air in supply line.</p> <p>Blocked flue ways.</p>	<p>Inspect and reset or remove blockage.</p> <p>Check and replace with correct size and type. (see Technical data).</p> <p>Check fan operation and cleanliness.</p> <p>Replace with nozzle of correct type and size. (see Technical data).</p> <p>Purge at pump to remove.</p> <p>Clean Heater and flue.</p>
<p>8. Burner locks out on morning starts then runs perfectly for rest of day.</p>	<p>Localised low voltage supply in early morning.</p> <p>Air present in oil supply.</p> <p>Bottom of oil tank below level of oil pump.</p> <p>Non-return valve faulty or air leak in two pipe oil supply system.</p>	<p>Check with local Electricity Board to fit recorder, enlist aid of the Board.</p> <p>Restart burner several times - press lockout reset button, repeat 7(b) above.</p> <p>Raise tank or install a two pipe oil supply from tank.</p> <p>Renew non-return valve. Rectify air leak.</p>
<p>9. Burner fails due to blown fuse.</p>	<p>Short circuit in wiring.</p> <p>Motor seized.</p> <p>Breakdown of insulation of motor windings,</p>	<p>Inspect wiring, sheathing and inter-component connections for broken or damaged leads. Replace if necessary.</p> <p>Check by hand and replace if necessary.</p> <p>Replace motor.</p>
<p>10. Burner runs normally but will not reach desired temperature.</p>	<p>Oil throughput insufficient.</p> <p>Low efficiency and CO₂.</p> <p>Low efficiency due to high flue gas temperature.</p> <p>Faulty Control stat.</p> <p>Partially blocked filter.</p>	<p>Check nozzle size and pressure against rating.</p> <p>Check combustion readings, reset air.</p> <p>Clean heat exchanger surfaces.</p> <p>Replace, check and clean.</p>
<p>11. Poor Combustion readings</p>	<p>Low CO₂.</p> <p>High CO₂.</p> <p>High Smoke.</p> <p>High flue gas temperature.</p>	<p>Check: air shutter, oil pressure, nozzle size. (see Technical data).</p> <p>Check: air shutter, oil pressure, nozzle size, fan impeller blades, for cleanliness.</p> <p>Check: air shutter, nozzle size (see Technical Data) and burner head geometry. Check all baffles are in place and correct.</p> <p>Check: air shutter, nozzle size (see Technical Data) Clean heat exchanger surfaces.</p>

<i>Trouble or Complaint</i>	<i>Possible Cause</i>	<i>Action</i>
12. Oil odours.	Leaking joints.	Break all leaking joints and re-make.
13. High operating temperature.	Control stat failed and operating on limit stat.	Replace control stat and reset Limit thermostat.
14. Fumes in Heater Room.	Inadequate draught due to unsatisfactory chimney or blockage of Heater flue ways or flue pipe.	Take necessary corrective action.
15. Unstable flame, some puffing, ignition cuts in intermittently.	Air damper on burner improperly adjusted or faulty nozzle or unsatisfactory draught conditions or fault in oil supply.	Set up burner as for commissioning using oil pressure gauge, smoke pump, CO ₂ indicator and draught gauge, adjust settings as necessary, replace nozzle if necessary. See Commissioning Check List and Servicing Notes.

Certikin

Station Lane
Industrial Estate
Witney
Oxon.

Tel. 01993 778855
Fax. 01993 703407