

COMPLETE SANITATION SYSTEM

Natural Pool Water Treatment

CSS 10 — Ozone/Salt Chlorinator

For Residential Pools Up to 15,000 Gallons

Prozone has combined ozone and salt together in one Complete Sanitation System for your pool



T-O₃ NATURAL TECHNOLOGY

Reduces Chemical Usage,
Improves Sanitation, Eliminates Odors
Produces Crystal Clear Water

IMPORTANT SAFETY INSTRUCTIONS

Read and Follow All Safety Instructions

- Read and be familiar with this manual before installing, operating, or performing maintenance on the CSS 10.
- Voltage must be determined before unit is installed.
- The CSS 10 must be installed in accordance with the installation instructions and diagrams provided in this manual.
- The CSS 10 power supply must be mounted vertically on a flat surface and a minimum of 5 feet from the pool.
- Use only the power cord (DC Voltage) provided with the CSS 10.
- Canada and some other regional codes mandate the use of GFCI protected circuits. If installation is completed by a licensed electrician or pool equipment installer, they will be required to verify this requirement for your area and comply during installation



WARNING: Disconnect all power to pool equipment prior to installation, maintenance, or removal of the CSS 10.



WARNING: Do not permit children to operate this product



WARNING: To avoid risk of electric shock, fire, or injury, service should only be performed by a qualified pool service professional.



WARNING: Installation must be performed in accordance with the National Electric Code and any applicable local or state installation codes.



WARNING: When mixing acid with water, ALWAYS ADD ACID TO WATER, NEVER WATER TO ACID.

SAVE THESE INSTRUCTIONS

Table of Contents

Section 1 Product Information	4
1.0 Recorded Information Sheets	4 & 5
1.1 Introduction	5
1.2 Customer Responsibilities	5
1.3 How Does It Work	6
Section 2 Installation	7
2.1 Installation Guidelines	7
2.2 Verify Contents	8
2.3 Quick Start Installation Guide	8
2.4 Installing the P34 bypass kit	10
Section 3 Pool Preparation	11
3.1 Start Up Procedures	11
3.2 Preparing Your Pool	11
3.3 Adding Salt	11
3.4 Balance Pool Chemicals	12
3.5 Pool Circulation	12
3.6 Pool Preparation Warnings	12
Section 4 Chlorine Cell Maintenance	13
5a Cell Maintenance	13
5b Calcium Deposits	13
5c Acid Wash Instructions	13
Section 5 Winterization and Spring Start-Up	13
Section 6 Warranty Information	14
Warranty Registration Page	15
Section 7 Trouble Shooting Guide	16

Save This Information for Future Use

Installer:	Date of Installation:
Control Box Model Number: CSS 10	Control Box Serial Number:

Manufactured by
Prozone Water Products
2610 6th St.
Huntsville, AL 35805

Visit us on the Web
www.prozoneint.com

1.1 Introduction

Congratulations! You have purchased one of the most technologically advanced Pool Sanitation Systems in the world. The CSS 10 Ozone/Salt Chlorine Generator (Advanced Oxidation Processor™) is the most powerful solution for Sanitation and Oxidation requirements in your pool, the benefits of which will be evident from the very first time you use it and for many years to come.

1.2 Customer Responsibilities

Record the Following Information at Initial Installation of your CSS 10 Unit

Start-Up Water Analysis	
Date _____	Levels
pH	
Alkalinity	
TDS (Total Dissolved Solids)	
Cyanuric Acid (Stabilizer)	
Salt Levels	
Free Chlorine	
Calcium Hardness	
Metals	
Nitrates / Phosphates	
Saturation Index	

Proper Water Chemistry is Important to Protect Your Valuable Investment

The above information will be required for Technical Support conversations.
This information must be provided in the event a warranty claim is requested.

- ◇ Complete and mail in your warranty page included in this manual. Your warranty is not valid until this product is registered, and must be completed within 30 days of installation. You may register your unit by e-mail to, CSStechnicalsupport@prozoneint.com. Type Product Warranty in the subject box, and include in the body of your e-mail: 1. Name 2. Complete Address 3. Phone Number 4. Product Model number and Serial number, 5. Date of Installation. Keep your original sales receipt in case product needs to be serviced.
- ◇ Proper water balance must be maintained to protect your valuable investment.
- ◇ Ensure that your CSS 10 unit has been properly installed.
- ◇ Check the Chlorine Generator Cell often; follow Cell Maintenance instructions in this manual located in Section 4.
- ◇ Increase Chlorine Production percentage as warm temperatures increase.
(Hot weather conditions make it more difficult to maintain proper chlorine levels)
- ◇ Refer to our website for information on Basic Pool Chemistry at: www.prozoneint.com/manuals.php

△ **WARNING:** Failure to follow these maintenance instructions, and all other specified operating procedures might void the warranty of this product.

The Table below summarizes the levels that are recommended by The Association of Pool and Spa Professionals (APSP). It is important to maintain these levels in order to prevent corrosion or scaling and to ensure maximum enjoyment of the pool. Test your water periodically. Take a water sample in to be professionally tested by a Pool and Spa Professional at least once a month. Be sure to tell your local Pool Store that you are using a Complete Sanitation System, Ozone/Salt Chlorine Generator Combination System.

pH	7.2 to 7.6
Alkalinity	80 – 120 ppm
TDS	Less than 1,000 Excluding Salt
Cyanuric Acid	30 – 70 ppm
Salt Levels	2500 to 3000 ppm
Free Chlorine	.5 to 1.5 ppm
Calcium Hardness	60 to 400 ppm
Metals	0 ppm
Nitrates / Phosphates	<30 ppm

1.3 How Does it Work

Description:

Your CSS 10 System produces both ozone and chlorine. The Ozone Generator produces ozone with light energy, the way the sun does. Therefore, it is only emitting pure O₃ ozone that has no harmful by-products, unlike other ozone generators that use corona technology which produce nitrous acid compounds and other harmful byproducts. Ozone is a molecule of oxygen that is formed when three atoms of oxygen are bound together instead of the normal two atoms. The extra oxygen atom makes ozone the most powerful, naturally occurring oxidizer and sanitizer readily available. Pioneers of the original ozone generator cartridge, produced the first Ultraviolet Ozone Generating cartridge in 1977 for the swimming pool and spa industry.

The O₃, naturally produced ozone, generated by the CSS 10 System serves as the primary sanitizer and oxidizer, however, a small residual of free available chlorine is required at all times to control algae growth and provide a residual sanitizer requirement.

The CSS 10 System provides the necessary chlorine residual for your pool. A measured amount of pool salt is dissolved in the pool water. The Chlorine is made by passing a very low voltage electric current through the salt water as it flows through the Cell and back in to the pool.

The CSS 10 System (Advanced Oxidation Processor™) produces and combines ozone and chlorine. These super oxide compounds, even stronger oxidizers than ozone or chlorine alone, are injected in to the pool water through a patented Venturi Bypass Installation process.

While the initial costs of the system may seem sizable, the savings begin immediately. Using your CSS 10, you will eliminate almost all chlorine purchases. You will produce chlorine in your own backyard for pennies a gallon. In addition to the cost savings, you have eliminated the need to transport and store potent chlorine oxidizers and sanitizers. In most parts of the country, the costs are recovered in three to four seasons.

Specifications:

CSS 10	
Power Requirements	110VAC or 220VAC
Operating Temperature	Air: 25°F to 140°F Water: 59°F to 110°F
Ozone Specifications	.4g/hr @ 110°F @ 60% RH
Salinity PPM	1500 to 4000 PPM 2500 PPM nominal
Chlorinator Production	7 g/hr
Pool Capacity	Up to 15,000 Gallons
Water Flow Rate	2 to 12 gpm
Dimension Specifications	16.5" X 9" X 4" 10.2 lbs.

Section 2

Product Installation

2.1 Installation Guidelines

- ◇ The CSS 10 must be correctly installed or your system may not work properly and the warranty will be voided.
- ◇ The CSS 10 should be installed on residential pools only.
- ◇ A qualified swimming pool professional and certified electrician must install the CSS 10.

2.2 Verify Contents

Verify that you have the following parts prior to starting installation. (For assistance, contact Prozone Customer Service at 256-539-4570)

P19 Installation Kit - In Ground Pools
Refer to this list when ordering replacement parts

Description	Part Number	Quantity
684 Venturi Injector	600002	1
Plastic Clamp 1/2"	20185	2
Metal Clamp 1-1/4"	20067	2
Polybraid Hose 1/4"	20260	96"
Polybraid Hose 3/4"	201207	96"
Ball Valve 2"	20242	1
PVC Fitting 2"SP x 1-1/2"SL	201114	2
Saddle Clamp, Outer Top	201155-4	2
Saddle Clamp, Outer Bottom	201155	2
Saddle Clamp, Inner Top	201155-2	2
Saddle Clamp, Inner Bottom	201155-3	2
Saddle Clamp Gasket	400076	2
Saddle Clamp Bushing	201155-5	2
Screw #14 x 1-1/2" PPMS	201863	4
Nut 1/4-20	20703	4

P34 Installation Kit - Above Ground Pools
Refer to this list when ordering replacement parts

Description	Part Number	Quantity
684 Venturi Injector	600002	1
Plastic Clamp 1/2"	20185	2
Metal Clamp 1-1/4"	20067	6
Metal Clamp 2"	20069	2
Polybraid Hose 1/4"	20260	96"
Polybraid Hose 3/4"	201207	96"
Ball Valve 1-1/2"	20544	1
PVC Fitting 1-1/2"SL x HB	201826	2
PVC Fitting 1-1/2"S x 3/4" FPT	201097	2
PVC Fitting 3/4" MPT x HB	20678	2
PVC Pipe 1-1/2"	20381	6"

2.3 Quick Start Installation Guide

Before installing this product, turn pump off

CSS 10 Mounting Instructions

- Your CSS 10 can be mounted outside near the pump and filter, or on your above ground pump platform
- The holes in the mounting plates of the unit are for mounting on a wood post in the ground near the above ground pool equipment, or on a wall near the pump for an inground installation.
- Use appropriate mounting screws and hardware (not included) for the type of material you will be mounting to: brick, siding, concrete, etc.
- Make sure the Control Box is mounted in the vertical position, level, with no obstruction of airflow.

Electrical System Connection *(Must be installed by a qualified electrician)*

- If it is possible to wire your unit directly to the pool pump circulation timer that is the best option.
- Install your CSS 10 unit so that it is running during the same time cycle as your circulation pump.

Note: Please have a qualified electrician install your unit

- If your CSS 10 is a 110 Voltage unit, DO NOT attempt to wire in to a 220 Voltage receptacle
- Mount your unit close enough to the return leg of your bypass so the wiring assembly for the Chlorine Cell is attainable.
- Install Chlorine Cell in to return leg of the bypass as shown in Figure 8.
- Connect the two lead wires from the Control Box to the matching lead wires in the Chlorine Cell as shown in Figure 2.

New plaster/gunite pool

- Disconnect the lead wires going from the Control Box to the Chlorine Cell.
- Do not add salt to the pool for at least 2 weeks, allow your pool surface to completely cure and harden.
- You may turn on your CSS 10 and allow water to flow through the cell, (this will not damage the cell).
- Run your CSS 10 while the pump is running so that your Ozone System can oxidize and purify your pool water.
- It may be necessary to add chlorine to pool water during this process. After pool surface is completely cured, refer to manual and add appropriate amount of salt.
- Turn unit off
- Reconnect Cell lead wires from Control Box to Chlorine Cell. (Figure 2) Turn unit back on and follow owner's manual for Mode Set Up instructions



(Figure 1)

Cell leads from control box

(Figure 2)

Cell leads from Chlorine Cell



Saddle Clamp Bypass Installation Instructions

1. Turn pump OFF.
2. Locate section of existing plumbing in which you choose to install the entrance leg of the bypass. Location should be in any accessible area after the pump, filter and heater.
3. Install Saddle Clamp Top & Bottom, (and adapters if needed), without Bushing and Venturi Injector.

NOTICE This will be used as a guide for your installation hole. See Figure 4.

4. Drill 7/8" hole through one wall of pipe, using power drill.

CAUTION: Do not drill too deep to avoid penetrating the opposite side in the plumbing.

5. Install Ball Valve between the entrance point and the exit point of the Saddle Clamp bypass. See Figure 5
6. Repeat steps 1, 2, 3 and 4 for exit of the bypass. Remove both Saddle Clamp Assemblies.

CAUTION: The bypass exit should always be after the heater. Damage to the heater may occur if the outlet of the bypass is installed prior to the heater.

7. Re-mount Saddle Clamp assemblies on both Entrance and Exit bypass locations (See Figures 6 & 7).

Note: For 2" pipe, do not use 1-1/2" adapters and gasket and turn Bushings so small end points toward Injector (for Entrance) or Chlorine Cell (for Exit).

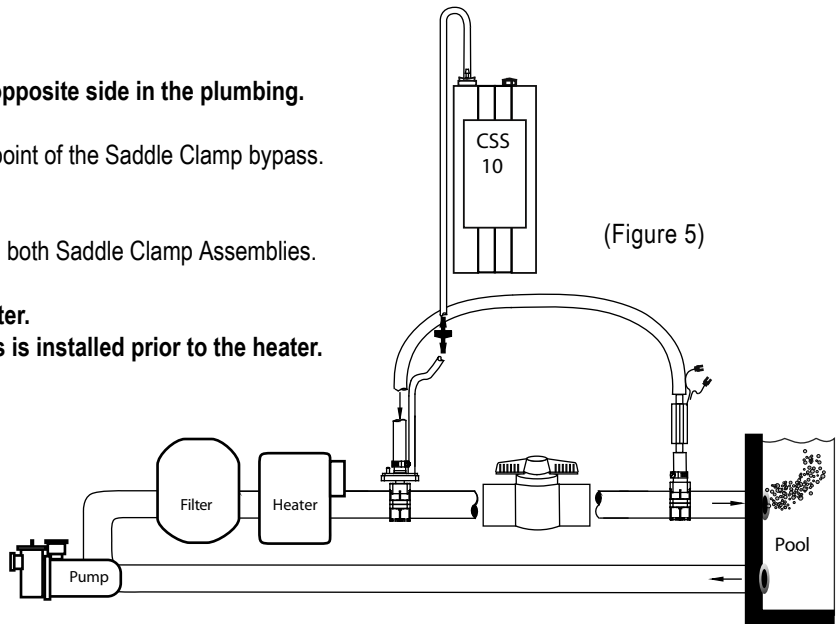
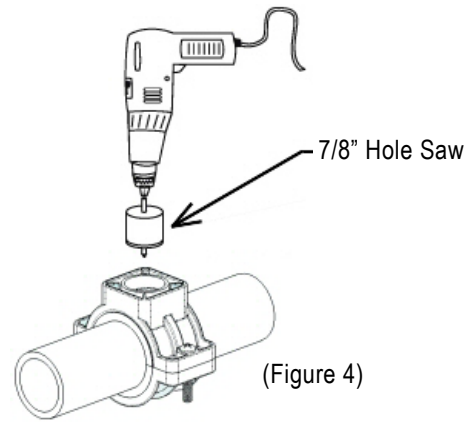

For bypass Entrance, (before Ball Valve)

- Using 1-1/2" pipe, Assemble:
 Venturi Injector (Note direction)
 Saddle Clamp Top & Bottom
 Top & Bottom Adapters
 Bushing (Note direction)
 Gasket
 Screws (2)
 Nuts (2)

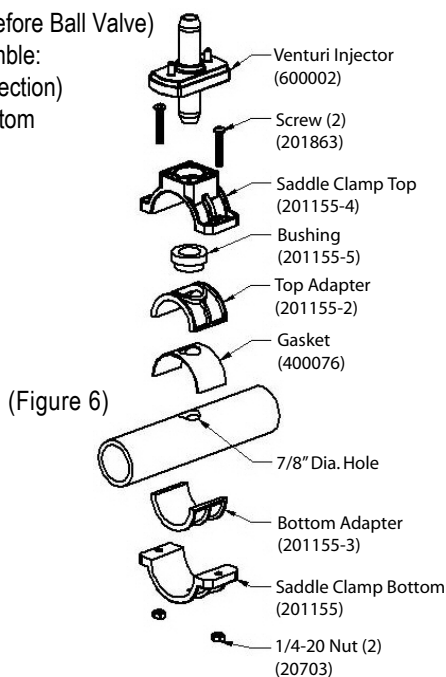

For bypass Exit, (after Ball Valve)

- Using 1-1/2" pipe, Assemble:
 Chlorine Cell (Note direction)
 Saddle Clamp Top & Bottom
 Top & Bottom Adapters
 Bushing (Note direction)
 Gasket
 Screws (2)
 Nuts (2)

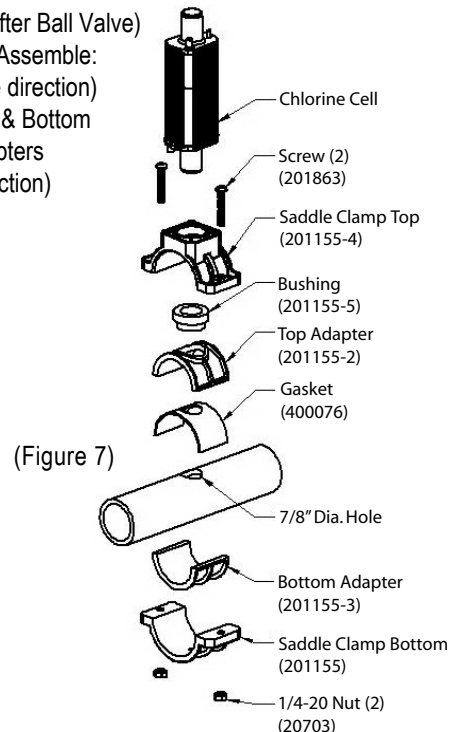

9. Attach 3/4" Tubing from Venturi Injector to Chlorine Cell as pictured. Fasten both with 1-1/4" metal hose clamps.

Your unit comes with check valve installed at factory.

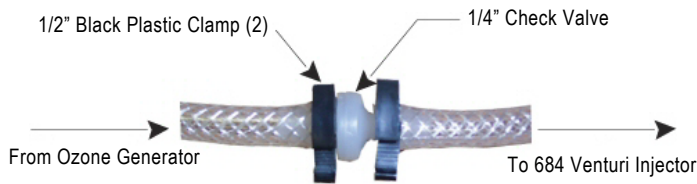

(Figure 10)



(Figure 9)

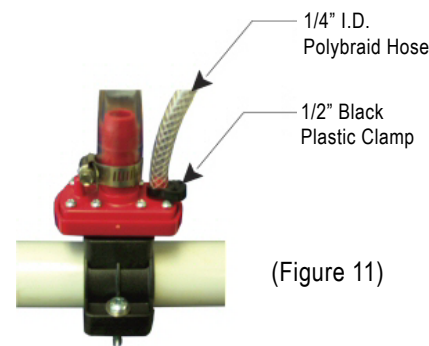

(Figure 11)

10. Connect 1/4" Polybraided Hose from Check Valve to Venturi Injector and fasten with 1/2" Black Plastic Clamps. (See Figure 11).

2.4 Installing the P34 bypass kit

The P34 Kit is for installing the CSS10 to an above ground pool. It will assemble to create a bypass system, to be installed on the return side of the pool plumbing after the filter, before the pool return.

Steps to assemble and install the P34 By-Pass Kit are as follows:

1. Saw the 6" piece of 1 1/2" PVC pipe in half, creating (2) 3" long pieces.
2. Using PVC glue, attach the 3" long PVC pipes to each end of the Ball Valve.
3. Glue the PVC Tee Fittings, 1 1/2"S x 3/4" FPT, to each end of the PVC pipes, making sure to keep both fittings in line with the Ball Valve.
4. Glue the PVC barbed Fittings, 1 1/2"SL x HB, to each end of the PVC Tee Fittings.
5. Using Teflon tape, screw the PVC barbed Fittings, 3/4"MPT x HB, into the PVC Tee Fittings.
6. Locate the 3/4" polybraided hose and cut (2) 4" long pieces from it.
7. Attach each of the 4" long 3/4" hose pieces to the 3/4" PVC barbed fittings using the 1 1/4" metal clamps. Tighten clamps.
8. Slide one more metal clamp on each piece of the 3/4" polybraided hose but do not tighten.
9. Attach the Venturi Injector to one of the 3/4" polybraided hose pieces with the ports facing upward. Tighten clamp.
10. Attach the Chlorine Generator Cell to the other 3/4" polybraided hose piece with the terminals facing upward. Tighten clamp.
11. Slide the remaining (2) metal clamps over the remaining piece of 3/4" polybraided hose, (you should have approximately 88" left).
12. Attach each end of the 3/4" polybraided hose to the Injector and Chlorine Cell, creating a full loop. Tighten clamps.
13. Attach the 1/4" polybraided hose to the open port of the Injector and secure with a 1/2" black plastic clamp.
14. At this point, the P34 Kit is assembled and ready to install in your pool system.
15. Locate a convenient place for your new P34 By-Pass. It may be mounted to a wall or a post, or can simply be placed on the ground with the 3/4" polybraided hose loop leaning against the pool or the wall/post the CSS 10 Control Box is mounted to. It will not harm the P34 By-Pass to rest on the ground.
16. Connect the end of the P34 By-Pass, closest to the Injector, to the hose coming from the filter outlet and secure with a 2" metal clamp.
17. Connect the other end of the P34 By-Pass, closest to the Chlorine Cell, to a hose going back into the pool. It may be necessary to purchase another piece of flexible tubing from your pool supplier for this.
18. Connect the other end of the 1/4" polybraided hose to the 1/4" Check Valve on the CSS10 and secure with a 1/2" black plastic clamp.
19. Connect the wire terminals from the CSS10 to the Chlorine Cell terminals.

Your By-Pass system is now installed, complete, and ready to use.

3.1 Start Up Procedures

Establishing Water Balance

While the CSS 10 systems are designed to reduce the amount of chemical care — *it does not eliminate the need for water balance* Understanding how the unit fits into overall pool care is extremely important. Before starting your new sanitation system, you will need to bring a water sample to your local pool dealer for a full analysis.

There are two stages to clean, clear, safe water.

1. **Backyard Testing:** Your pool water should be checked one to two times per week for pH, Chlorine, and salinity (salt).
 - a. pH should be between 7.2 and 7.6. Any readings outside of this range needs to be corrected immediately.
 - b. Chlorine should be between .5 and 1.5 ppm (parts per million). Chlorine levels that are too high may require an output adjustment on your system. Chlorine levels that are too low may require salt addition or adjustment of the system.
 - c. Salinity should be between 2500 ppm and 3000 ppm. Levels that are too low will result in inadequate chlorine production, levels that are to high will result in over production. More is never better.
2. **Professional Testing:** A water sample needs to be brought to your Professional Pool dealer once a month to have the overall water balance checked.
 - a. Overall Balance In addition to verifying your readings, the dealer will also test for Alkalinity, Calcium, Stabilizer, and the presence of any unwanted minerals like iron and copper.

△ **WARNING:** Failing to properly balance your water may result in damage to the CSS 10 unit as well as the pool surface and equipment. Bathers will experience discomfort. Note: This and all related product warranties do not cover failure or damage caused by improper pool water balance.

3.2 Preparing Your Pool

- ◇ Test and balance the pool water. Pool water must be at the proper salinity level, and chemically balanced before operating the CSS 10. Refer to Table on page 6 for required levels. Pools should be balanced in this order:
 - 1) Balance pH to 7.2 - 7.6
 - 2) Shock pool with Chlorine to 20 PPM
 - 3) Brush pool
 - 4) Vacuum and back flush to dump
 - 5) Add required salt
 - 6) Wait 4 hours for pool to equalize
 - 7) Balance pH
 - 8) Run pump for 2 days and check chemical levels
 - 9) Check Filter

3.3 Adding Salt

- ◇ Test the salt level of your pool before calculating the salt requirement, particularly if a salt chlorine generator has been used, or sodium chloride has been previously added to the pool water. A salinity level of 2,500 to 3,000 ppm will allow for adequate chlorine generation. Salt should be added per the following formula to meet concentration requirements, providing the pool water has not already had any salt added to it:

21 pounds of salt for every 1,000 gallons of pool water

Pool gallons can be determined from the following formulas:

- Rectangular – Length x Width x Average Depth x 7.5 (for gallons) or x 1000 for liters.
- Round – Diameter x Diameter x Average Depth x 5.9 (for gallons) or x 785 for liters.
- Oval – Length x Width x Average Depth x 6.7 (for gallons) or x 893 for liters.

3.4 Balance Pool Chemicals

- ◇ Add Cyanuric acid (chlorine stabilizer) at the same time you add salt. Cyanuric acid helps maintain chlorine levels and it is required to maintain chlorine levels during hot weather. A pH buffer can also be added at this time. The appropriated concentration of Cyanuric acid is from 30 to 70 ppm.
- ◇ Before turning on the CSS 10, add Chlorine Shock to pool to reach 20 ppm for initial start up. Run the pool pump and Chlorine Generator for a minimum of 12 hours a day. The actual run time will be affected by the chlorine demand from the environment or bathers.
- ◇ The initial set up percentage of chlorine should be set at 50% for the first 3 to 5 days. Test and adjust the chlorine percentage until the chlorine requirement stabilizes and maintains 0.5 to 1.5 ppm of free chlorine.
- ◇ If the CSS 10 is being installed on a new plaster pool, do not add salt for 2 to 3 weeks after pool has been filled to help protect plaster, and to allow time for the plaster to cure. Follow your pool builder's suggestions on cure time allowance.

You may run your new CSS 10 system without salt in the pool. It will not harm the system, but will not generate chlorine until salt has been added. The patented Venturi Bypass Installation allows Ozone to flow in to the pool water. Ozone helps in the hardening process for plaster and gunite pools.

3.5 Pool Circulation

In order for your system to produce chlorine and effectively inject ozone in to the water, the circulation system must operate at optimum levels. Poor water flow, or short operating cycles will hamper the ability of the CSS 10 to work properly. Below are some of the guidelines for system operation:

- The pool pump/CSS System should operate a minimum of 12 hours per day. Running the system during the daylight hours is best.
- The filter should be cleaned or backwashed as described in the equipment manufacturer's manual. Filters that become clogged with debris will not allow proper water flow and may damage pool equipment including the CSS 10 generator.
- Skimmer and Pump baskets MUST be emptied regularly to keep the circulation system operating and prevent blockage.
- Debris should be removed quickly from the pool to prevent chlorine demand situations.
- Periodic brushing of pool surfaces prevents algae from growing and diminishing the effectiveness of the pools filtration and sanitation systems.

3.6 Pool Preparation Warnings

- △ **WARNING:** Do not use Copper or Bromine based algaecide products in your pool when the CSS 10 is installed
- △ **WARNING:** Always disconnect automatic pool cleaners before adding salt. Salt must be completely dissolved before turning on the pool cleaner.
- △ **WARNING:** Baquacil (Biguanide) pools must be drained and refilled with fresh water prior to using the CSS 10.
- △ **WARNING:** Use swimming pool grade salt ONLY (low mineral content sodium chloride)
- △ **WARNING:** Do not attempt to add salt via the skimmer, this could damage the filter and pump. Keep the pump operating during this process.

Chlorine Dial

It is suggested that the initial setting should be to set the dial at position 2. After 24 hours check chlorine level and adjust as needed.



4.1 Cell Maintenance

Inspect the Cell plates once a week to ensure that they are clear of foreign matter and other debris.

NOTE: A filtration problem exists (contaminated water is by-passing the filter) if debris is found to have built up around the electrodes and plates of the Cell and should immediately be corrected.

4.2 Calcium Deposits

If calcium deposits form on the electrodes and plates, it may be caused by one of the following:

- a) Low Water Flow through the Cell – Check the hoses and the injector for blockage of water flow.
- b) Poor water Quality - High calcium content, High pH levels, clean cells (see below).
- c) Aged Cell – After 3-5 years loss of plate coatings may decrease the effectiveness of the self-cleaning process. Replace cell.

4.3 ACID WASH FOR REMOVAL OF CALCIUM DEPOSITS ON CELL PLATES

**WARNING: FOR QUALIFIED POOL PROFESSIONALS ONLY
DO NOT ATTEMPT THIS PROCEDURE WITHOUT PROPER TRAINING**

CAUTION: USE PROTECTIVE EYE WEAR, GLOVES, AND PROTECTIVE CLOTHING

1. Turn PUMP OFF and allow water to drain back out of the Cell and by-pass system.
2. Disconnect the ¼" Braided Hose from the Check Valve.
3. Place a bottle of Muriatic acid close to the Venturi Injector
4. Put the hose end into the container of Muriatic acid solution.
5. Turn the pump back on for approximately 1 minute or until Chlorine Cell is filled with acid.
6. Turn the pump off for 15 to 20 minutes to allow the solution to soak the plates.
7. Repeat Steps 5 and 6 above until the calcium build-up is gone.
8. Reconnect ¼" Braided Hose to Check Valve.
9. Turn PUMP ON.

NOTE: The solution entering the pool will not disturb the pH of the pool's water.

NOTE: If build-up is not removed, contact your local dealer or for additional advice.

Section 5

Winterization and Spring Start -UP

WINTERIZATION

Freezing water may damage the Cell's internal components and may cause cracks in the casing, voiding the Warranty. If severe, or extended periods of freezing temperatures are possible, drain all the water from the pump, filter and Chlorine Cell, supply and return lines before freezing occurs.

SPRING START-UP

Balance your pool and perform start-up as listed in this manual.

PROZONE® Advanced Oxidation Purification Products LIMITED WARRANTY

Warranty is offered on this unit for a period of 24 months from date of purchase, and extends only to the original purchaser. If this unit becomes unserviceable due to defects in materials or workmanship within 24 months from date of purchase, it will be repaired or replaced without charge. Warranty does not apply to breakage due to obvious misuse. Warranty period for a repaired or replaced unit applies to the original date of purchase of the unit. Manufacturer will repair or replace based on evaluation of returned unit.

In order to receive warranty service, a Returned Goods Authorization (RGA) number must be obtained from Prozone before returning the product. The RGA number must be issued prior to end of warranty period. Product must be returned within 30 days of issuance of the RGA number. If the product is not received by Prozone within 30 days of RGA number issuance, another RGA number must be obtained; RGA number must be obtained before warranty period expires.

This warranty along with the sales receipt must accompany the unit when it is returned. The RGA number must be printed prominently on the bottom left corner of the address side of the return packaging. To obtain an RGA number, or for any questions regarding warranty service, please contact:

PROZONE WATER PRODUCTS	email: sales@prozoneint.com
2610 6th Street, SW	Tel: (256) 539-4570
Huntsville, AL 35805	(800) 632-6462
	Fax: (256) 539-4225

This warranty is void if the unit has been opened, or if the product identification label has been removed or altered. This warranty does not cover damage resulting from misuse, abuse, accident, fire, flood, lightning or other acts of nature, lack of reasonable care, or subjecting the product to any but the specified voltage.

Under the terms of the warranty, manufacturer assumes no responsibility for any injury, loss or damage (direct, indirect, or consequential) arising out of the use of or inability to use the product. Manufacturer assumes no responsibility for labor involved in removal of defective part, shipping or installation of new part. This warranty gives you specific legal rights, and you may also have other rights which vary from state to state. This warranty is in lieu of all other warranties, express or implied.

RETURNS WITHOUT AN RGA NUMBER WILL BE REJECTED.

The Following Invalidates the Warranty:

1. Incorrect installation
2. Misuse or abuse
3. Failure to inspect the cell on a regular basis
4. Cell is used for any other purpose than described herein.
5. Operating the Cell at a pressures exceeding 30 psig
6. Operating the cell at salt levels lower or higher than recommended
7. Failure to winterize system

PLEASE COMPLETE THIS WARRANTY ON THE DAY OF INSTALLATION AND RETURN TO

PROZONE WATER PRODUCTS, INC.
2610 6TH STREET
HUNTSVILLE, AL. 35805

Failure to return this warranty information will void this warranty.

Date of purchase: _____

Purchased from: _____

Model Number: _____

Supplier Telephone No.: _____

Date of installation: _____

Installed by: _____

Name of purchaser: _____

Address: _____

City: _____ State: _____ Zip: _____

Telephone No.: _____

FAX number: _____

E-mail: _____

Residential application:

7.0 Trouble Shooting Guide

Low Chlorine In Pool

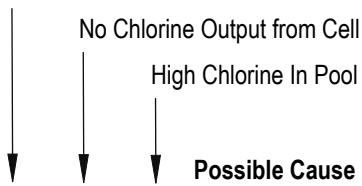

			Possible Cause	Possible Remedy
X			Low Salt	Test salt levels, add salt if required
X	X		Cell Dirty	Visually check cell, refer to manual for cleaning procedures
X			Poor Water Flow	Filter dirty / Bypass obstruction / leaves in basket
X			System Operation Time Too Short	Increase running time for pump and CSS unit
X			pH Range Too High	Add acid (hydrochloric or dry acid) refer to manual
X			Low Chlorine Stabilizer	Refer to manual, consult local pool professional
X			Chlorine Output % Set Too Low	Refer to manual for proper setting to get maximum chlorine output
X			Pool Filter Dirty	Refer to Filter owners manual for proper cleaning procedures
X	X		Pool Water Circulation Inadequate	Increase run time for pool pump, refer to pump manual
X	X		Pump Problems	Refer to pump owners manual
X	X		Excessive Air In Salt Cell	Check flow through Bypass
X	X		Unit Not Turned On	Turn Dial on top of unit to ON position
		X	High Salt	Dump pool water to skimmer, add fresh water / test salt levels
	X		Leads from Cell to Control Box not Connected / No Power to Cell	Refer to Quick Installation Guide for Cell Electrical Installation Power Leads from Control Box are not Connected